

92000

**ADVANCED REVERBERATION
PROCESSOR**

ZEN

High-Tech Tools for Artistic Expression

OPERATION MANUAL

Thank you for selecting the ZOOM 9200 Advanced Reverberation Processor (hereafter called "9200").

The 9200 is a sophisticated multi-effect device with the following features and functions:

- **99 preset effect programs centered around high-quality reverb-type effects make the unit immediately usable for recording, mix-down and other professional applications.**
- **32 effects including echo, chorus, and a newly developed sophisticated reverb algorithm let you easily create a wide range of original sounds.**
- **Well designed controls including an "analog feel" Dial allow quick effect switching and editing.**
- **Four input and output channels – unprecedented in this class – permit simultaneous processing of two stereo, two mono and one stereo, or four mono signals.**

Please take the time to read the supplied manuals carefully, in order to get the most out of your 9200 and to ensure optimum performance and reliability.

About the Manuals

The 9200 is supplied with three manuals:

Operation Manual

This is the manual you are reading now. It explains all controls and features of the unit, tells you how to connect it to other equipment and how to use the various modes. Even if you have previous experience with effectors, we recommend that you should at least browse through the various sections.

Parameter List

This manual lists all parameters for each effect, and explains what each parameter does.

Program List

The effects of the preset programs are listed here. Refer to this manual if you want to edit the preset programmed effects.

Safety Precautions

Please observe the following safety tips and precautions to ensure hazard-free use of the 9200.

Power Requirements

The voltage requirement for 9200 has been set specifically for the main supply voltage in your area. If it is to be used in an area with a different line voltage, please consult your local ZOOM distributor about acquiring a proper voltage converter.

Environment

Avoid using your 9200 in environments where it will be exposed to:

- Temperature extremes
- High humidity or moisture
- Excessive dust or sand
- Excessive vibration or shock

Handling

Since the 9200 is a precision electronic device, avoid applying excessive force to the switches and buttons. Also take care not to drop the unit, and do not subject it to shock or excessive pressure.

Alterations

Never open the case of the 9200 or attempt to modify the product in any way since this can result in damage.

Connecting Cables and Input and Output Jacks

You should always turn off the power before connecting or disconnecting any cables. Also make sure to disconnect all cables and the AC power cord before moving the 9200.

Caution!

The 9200 contains a backup battery which maintains the effect programs stored in the internal memory, even when the unit is turned off. The life of the battery is approximately 5 years. To avoid possible data loss, contact your local ZOOM distributor to have the battery replaced by a qualified technician after 5 years. Do not attempt to replace the battery by yourself, since installing an improper battery could result in an explosion.

Contents

Precautions	5
Terms Used in This Manual	6
Section 1 : Introduction	8
Names and Functions of Controls and Connectors	8
Front Panel	8
Rear Panel	11
Connections	12
Section 2 : Program Mode	13
To Activate Program Mode	13
Program Mode Display	13
Selecting a Program	14
Selecting a Preset Program Group	15
Adjusting the Input Level	16
Muting All Effects	17
Section 3 : Edit Mode	19
Program Configuration	19
Program Architectures	19
Effects	20
Effect Link Function	20
Pages and Parameters	22
To Activate the Edit Mode	22
To Cancel the Edit Mode	22
Basic Edit Mode Operation Steps	22
Selecting a Page or Parameter	22
Changing a Parameter Value	24
Selecting an Effect Module	24
Selecting the Effect	25
Editing a Program Name	25
Information About Storing Edited Programs	26
About the Active Buffer	26
Recall Confirmation	27
Program Change Confirmation	27

Section 4 : Edit Utility Mode	29
To Activate the Edit Utility Mode	29
To Cancel the Edit Utility Mode	30
Compare	30
Last Edit	31
Duplicate	33
Copy	33
Swap	36
Store	37
Storing a Program in the Same Location	37
Storing a Program in a Different Location	39
Verifying a Program at a Store Location	40
Section 5 : Utility Mode	41
To Activate the Utility Mode	42
To Cancel the Utility Mode	42
MIDI	43
1 Basic channel setting (MIDI Basic Ch)	43
2 MIDI receive on/off (MIDI Recv)	43
2-1 Receive program change on/off (MIDI Recv Prog Change)	43
2-2 Bank select receive on/off (MIDI Recv Bank Select)	44
2-3 System exclusive receive (MIDI Recv Dump)	44
3 Transmit information on/off (MIDI Trans)	45
3-1 Program change transmit on/off (MIDI Trans Prog Change)	45
3-2 Bank select transmit on/off (MIDI Trans Bank Select)	45
3-3 System exclusive transmit (MIDI Trans Dump)	46
3-4 MIDI Thru on/off (MIDI Trans MIDI Thru)	46
4 Program change number mapping (MIDI PC # Map)	47
System	47
1 Program auto load on/off (Prog Auto Load)	47
2 Input mode setting (Input Mode)	48
CARD	50
1 Load programs from card to user area (CARD Load)	50
2 Save programs from user area to card (CARD Save)	51
3 Verify a card (CARD Verify)	51
Formatting a RAM Card	52
Store	52
Mounting the Unit in a Rack	53
SPECIFICATIONS	54
MIDI IMPLEMENTATION	55

Precautions

Electrical Interference

The 9200 uses digital circuitry that may cause interference and noise if placed too close to other electrical equipment, such as TV sets and radio receivers. If such problems occur, move the 9200 further away from the affected equipment. Also, when fluorescent lights or devices with built-in motors are in close proximity to the unit, the 9200 may not function properly.

Cleaning

Use a soft, dry cloth to clean the 9200. If necessary, you may slightly moisten the cloth. Do not use any abrasive cleansers, waxes, or solvents (such as paint thinner or cleaning alcohol), since these may dull the finish or damage the surface.

In Case of Malfunction

If a problem arises during operation, turn the 9200 off and disconnect all cables. Then contact your local ZOOM distributor with the following information: model name, serial number, symptom, your name, address and phone number.

Keep this manual in a convenient place for future reference.

Terms Used in This Manual

Program

Up to four effects can be used by the 9200. Such a combination of effects, together with their parameter settings, can be given a name and stored as a program.

Effect Type

The 9200 has a total of 32 effects which are divided into the three effect types A, B, and C. The effect types differ according to the processing principles that are employed. For a list of effects, please refer to page 20.

Effect Module

To be used by the 9200, an effect is placed into an effect module. Each effect module contains one effect.

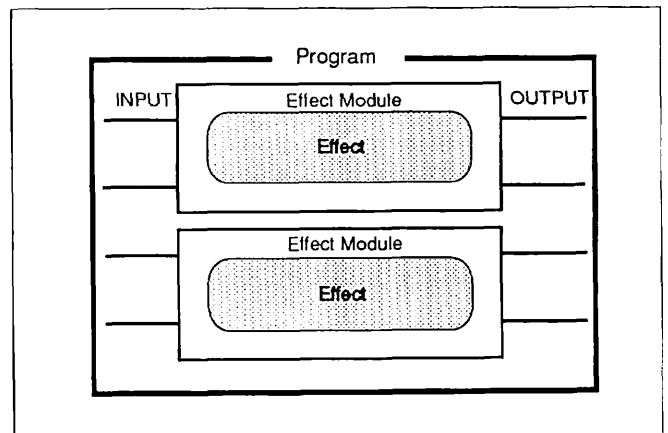

Program Architecture

The programs of the 9200 can be divided into four so-called program architectures which differ regarding the number and type of effects and the input/output configuration.

• Architecture I

Uses one set of stereo inputs and outputs. Only one effect can be used in this program architecture (effect type C in effect module 1).

• Architecture II

Uses two sets of stereo inputs and outputs. Up to two effects can be used in this program architecture (effect type B in effect modules 1 and 2).

• Architecture III

Uses two monaural inputs and outputs and one set of stereo inputs and outputs. Up to three effects can be used in this program architecture (effect type B in effect module 1, effect type A in effect modules 2 and 3).

• Architecture IV

Uses four monaural inputs and outputs. Up to four effects can be used in this program architecture (effect type A in effect modules 1, 2, 3, and 4).

Area

The location where a program is stored is called an area. The 9200 has a preset area (read-only) and a user area (read and write). Each of these two areas has room for 99 programs (numbered from 1 to 99). In addition, a ROM card and RAM card can also be used.

Active Buffer

The data read from an area are temporarily placed in a buffer called the active buffer. When you are selecting or editing a program with the 9200, the sound you hear is that of the program in the active buffer.

Parameter

The sound of an effect is determined by its parameter values. With the 9200, you can select the parameters for each effect and store them in a program.

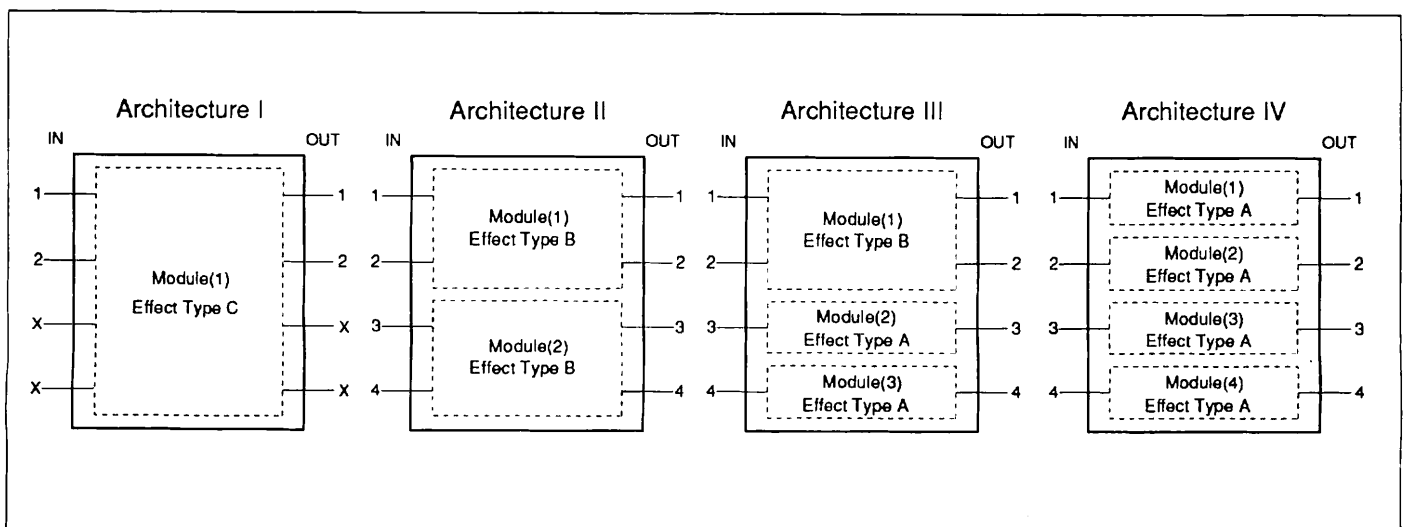

Program Architecture Configuration

Mode

Operation of the 9200 is divided into the following four modes.

•Program mode

The basic operation mode in which you select and use a specific program.

•Edit mode

The mode to edit the parameter values of a program.

•Edit Utility mode

This mode includes functions such as Compare Edit (listening to the sound before and after changes) and Last Edit (recalling the last edited parameters).

•Utility mode

Operations such as selecting MIDI channels, storing programs, etc. are carried out in this mode.

Page

A group of parameters that can take up 1 to 4 display screens is called a page. Each mode has several pages. To make a setting, you select the desired parameter from the respective page.

• Effect Link

If a program comprises more than one effect module, the effect modules can be linked in a serial or parallel configuration to create complex effects. This is called an effect link.

Section 1 : Introduction

This section explains the naming and function of controls on the 9200, and the connection to other equipment.

Names and Functions of Controls and Connectors

Front Panel

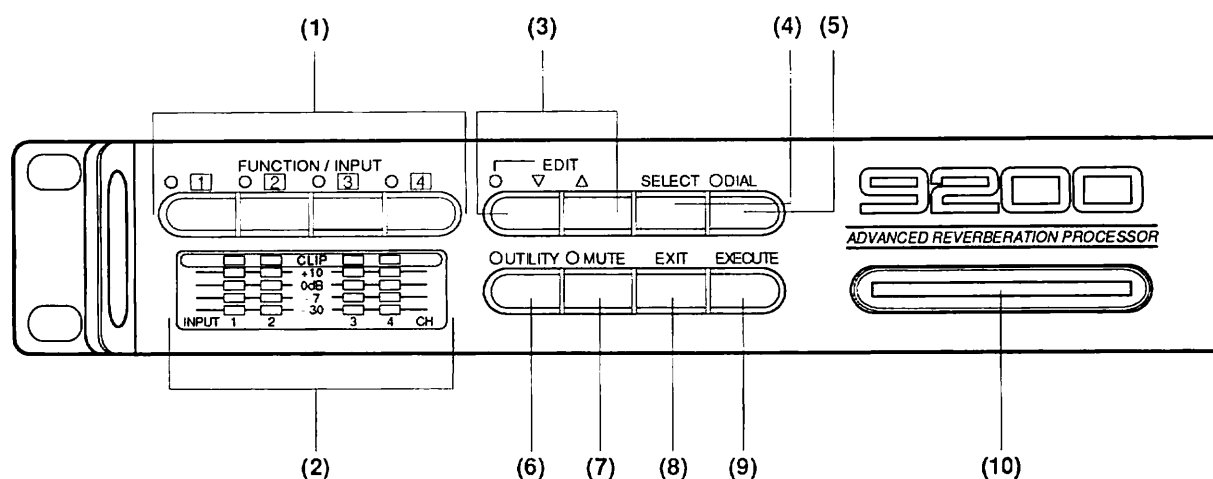

(1) FUNCTION/INPUT 1 - 4 keys

- **Program mode:**
Select the channel for input level adjustment.
- **Edit mode:**
Select the parameter to be edited.
- **Edit Utility mode:**
Select menus or parameters.
- **Utility mode:**
Select menus.

(2) Peak level indicators

Show the input level for INPUT 1 - 4. If the red indicator lights, the input level in that channel is high enough to cause distortion.

(3) EDIT▼/▲keys

- **Program mode:**
Serve to activate the Edit mode.
- **Edit mode:**
Serve to select the page and parameter to be edited.

(4) SELECT key

- **Edit mode:**
Selects the effect module and character position.
- **Edit Utility mode:**
Moves the cursor, selects the character position, etc.
- **Utility mode:**
Moves the cursor, serves to check an existing program at a storage location, etc.

(5) DIAL key

- **Program mode:**
Switches preset program groups.
- **Edit mode:**
Sets the unit for parameter value change.
- **Edit Utility mode:**
Sets the unit for parameter value change.
- **Utility mode:**
Sets the unit for parameter value change.

(8) EXIT key

In every mode, this key serves to return to the preceding page. When at the top page, the key terminates the current mode and returns to the previous mode (except in Program mode).

(9) EXECUTE key

In every mode, this key serves to execute a function or to confirm an entry.

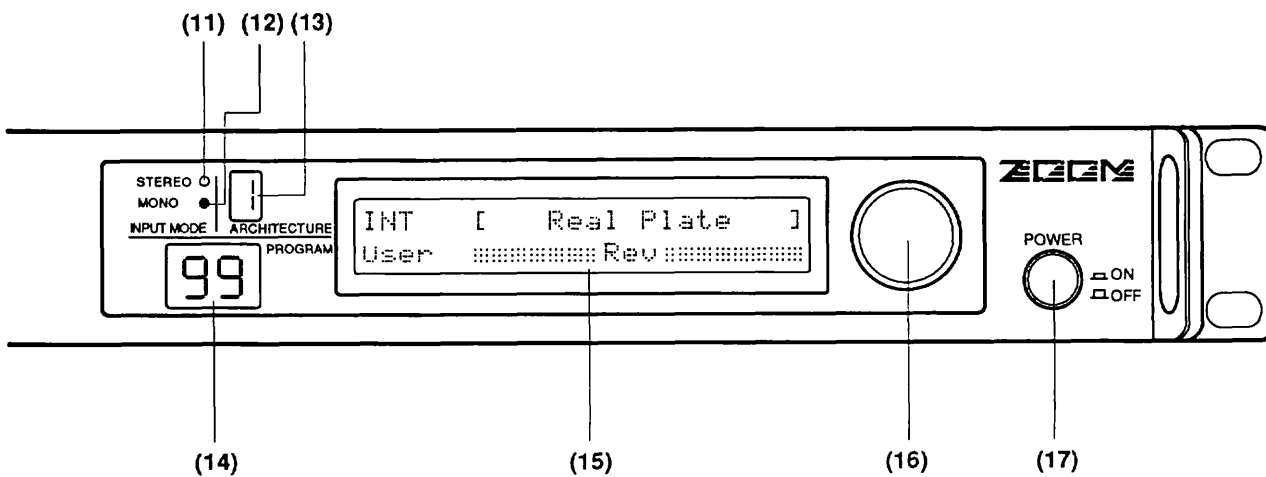

(6) UTILITY key

- **Program mode:**
Activates the Utility mode.
- **Edit mode:**
Activates the Edit Utility mode.
- **Edit Utility mode:**
Returns to the Edit mode.
- **Utility mode:**
Returns to the Program mode.

(10) Card slot

The optional RAM or ROM card is inserted here.

(11) STEREO indicator

Lights up when stereo is selected as input mode. For a detailed explanation of input modes, please refer to page 48.

(12) MONO indicator

Lights up when mono is selected as input mode. For a detailed explanation of input modes, please refer to page 48.

(13) ARCHITECTURE indicator

Shows a number from 1 to 4, indicating the current program architecture (I to IV).

(7) MUTE key

Switches the mute function (all effects on/off) in every mode.

(14) Program indicator

Shows the number of the currently selected program.

(15) Display

Shows various information for operation of the 9200, such as program names, effect parameter values, etc.

(16) Dial

• **Program mode:**

Serves to select a program and adjust the input level.

• **Edit mode:**

Serves to change the value of a parameter.

• **Edit Utility mode:**

Serves to change the value of a parameter, select the store target, or select the copy/swap source.

• **Utility mode:**

Serves to change the value of a parameter or select the store target.

(17) POWER switch

Push this switch to turn the 9200 on, and push it again to turn the unit off.

Rear Panel

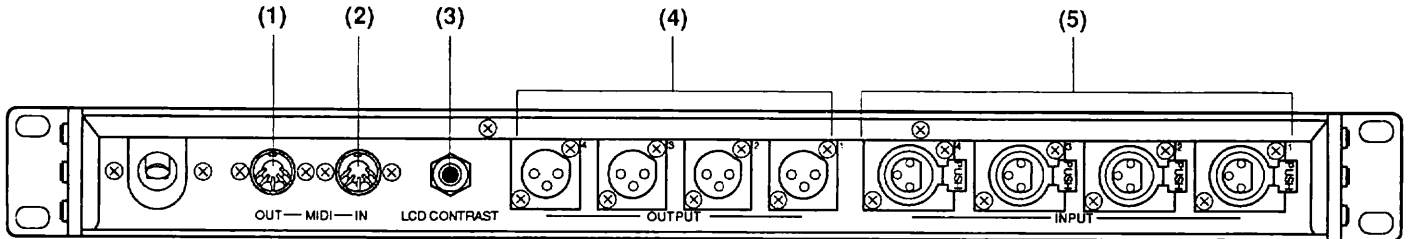

(1) MIDI OUT jack

Serves to send MIDI signals to other MIDI equipment. The jack also functions as a MIDI THRU jack.



The 9200 has balanced inputs rated for +4 dBm and unbalanced outputs rated for +4 dBm.

(2) MIDI IN jack

Serves to receive MIDI signals (such as program change or bulk data) from other MIDI equipment.

(3) LCD CONTRAST control

Adjusts the display contrast. Turning the control clockwise will make the display brighter.

(4) OUTPUT 1 - 4 jacks

To be connected to the inputs or the effect return jacks of a mixer or other equipment.

(5) INPUT 1 - 4 jacks

To be connected to the bus outputs or the effect send jacks of a mixer or other equipment.

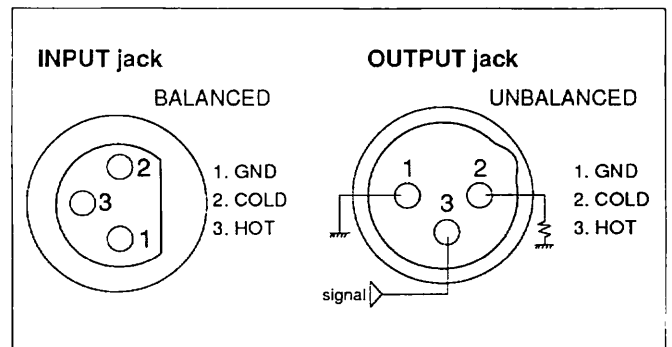

Input and Output Pin Diagram

Connections



1. Connect the power cord.

Plug the power cord of the 9200 into an AC outlet. Do not yet turn the unit on.

2. Connect a mixer or other external equipment.

Connect the bus output or effect send jack(s) of a mixer or other equipment to the input(s) of the 9200. Then connect the output(s) of the 9200 to the input or effect return jack(s) of the mixer or other equipment.

When wishing to control program changes of the 9200 via a MIDI signal from a sequencer or computer, connect the MIDI OUT jack of the other equipment to the MIDI IN jack of the 9200, and the MIDI OUT jack of the 9200 to the MIDI IN jack of the other equipment, using suitable MIDI cables.

There are many ways to connect the 9200, depending on the available equipment and the programs to be used.

When both the input and output lines are in stereo, use the INPUT and OUTPUT jacks numbered 1/2 and 3/4 on the 9200 as stereo pairs.

When wishing to have a stereo output from a mono input, use INPUT jack 1 and OUTPUT jacks 1/2, and INPUT jack 3 and OUTPUT jacks 3/4.

Note that INPUT jacks 3/4 and OUTPUT jacks 3/4 are not active for programs of architecture I.

3. Turn on power to the equipment in the following order:

- 1) 9200
- 2) Mixer
- 3) Playback system

This serves to prevent speaker damage due to turn-on thumps. To turn the equipment off, reverse the above sequence.

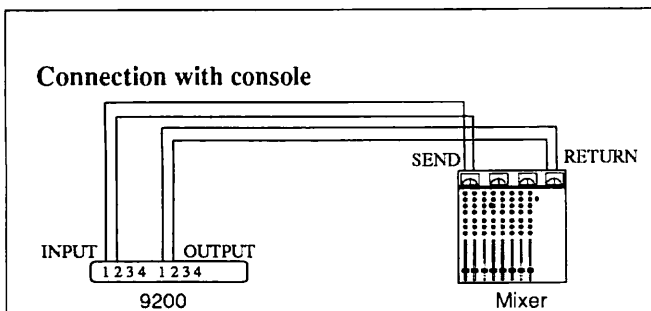

Connection Example 1

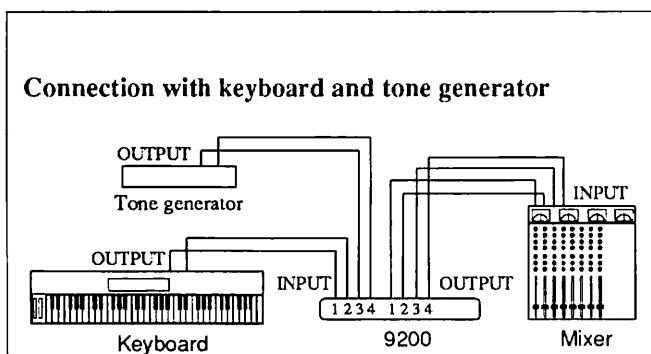

Connection Example 2

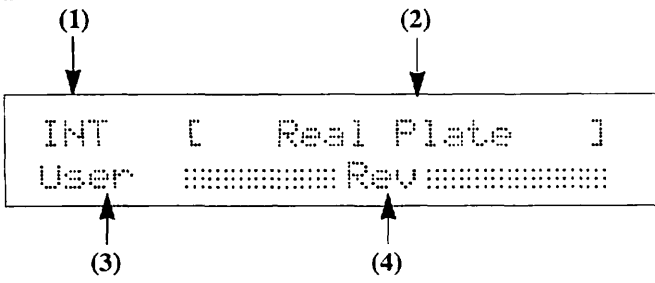

- (1) Medium type: INT (= Internal) or CARD
- (2) Program name
- (3) Area: ZOOM (= Preset) or User
- (4) The effect(s) of the currently selected program



NOTE
 The display shown above is only an example. In actual use, the display will be different depending on the status of the 9200 before it was last turned off.

Selecting a Program

Programs are selected by turning the Dial in Program mode. With every click, the program number changes by one count. Turning the Dial clockwise switches up and turning the Dial counterclockwise switches down. The range of numbers covers the preset programs 1 - 99, then the user programs 1 - 99, and finally the card programs 1 - 99 (when a ROM card or RAM card is inserted).



When a preset program or user program is selected, the 9200 loads its data into the active buffer. Since the sound heard from the output is that modified by the buffer, it changes constantly with each Dial click, as new programs are loaded. If you know the desired program and do not want to hear the effect of other programs, it is also possible to first call the program with the Dial and then press the EXECUTE key to actually select and load the program. (Refer to page 47 for details.)

If the Dial is turned in this condition, the program name is shown on the display, but the program indicator flashes to indicate that the program is not yet activated.

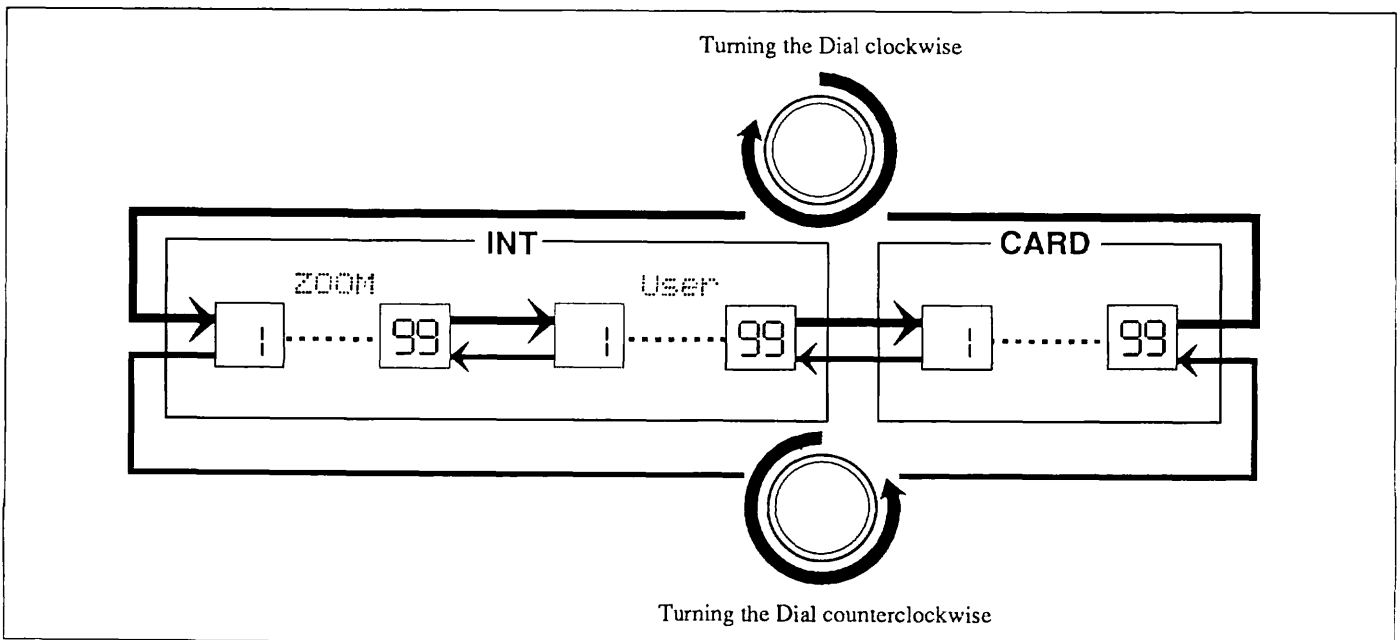

The Relationship of Dial turn direction and program areas

Pressing the EXECUTE key in this condition will select the program and cause it to modify the output sound.

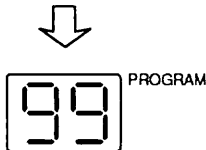
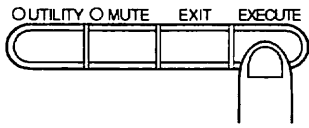
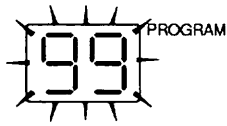

If the EXIT key is pressed, the program is not selected and the previous program remains active.

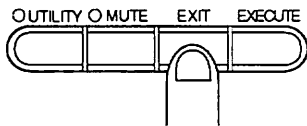

Selecting a Preset Program Group

The programs in the internal preset area and on the external ROM card are divided into several groups. Using the DIAL key and the Dial, you can select a group, to give you quick access to a desired program.

1. In the Program mode, select a program in the preset area or the ROM card and press the DIAL key.

The indicator of the DIAL key lights up, and the group name of the currently selected program is shown on the display.

```
INT [ Real Plate ]
ZOOM : : : : : Rev : : : : :
```

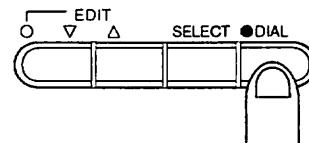

```
INT Plate Group
ZOOM
```

2. Verify that the indicator of the DIAL key is lit, and turn the Dial clockwise by one click.

While the indicator of the DIAL key is lit, turning the Dial will switch between program groups. The program indicator will flash, and the name of the next group is shown on the display.

```
INT Plate Group
ZOOM
```

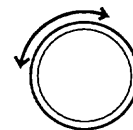

```
INT Hall Group
ZOOM
```

3. Press the EXECUTE key.

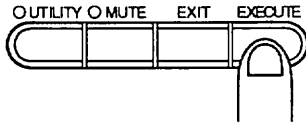

The indicator of the DIAL key goes out, and the first program of the new program group is selected.

If you press the EXIT key or the DIAL key instead of the EXECUTE key, the indicator of the DIAL key goes out and the 9200 reverts to the normal program selection mode, with the previous program still selected.



• Whenever a new program group is chosen, the first program in that group is selected. For a detailed explanation of available program groups, please refer to the Program List.

• Similarly to normal program selection, it is possible to set up the unit so that the EXECUTE key must be pressed once more after selecting a group to select a program. For details, please refer to page 47.

Adjusting the Input Level

The 9200 allows you to set the input level individually for inputs 1 - 4.

1. Press one of the FUNCTION 1 - 4 keys in Program mode, to select one of the inputs 1 - 4.

The indicator of the respective FUNCTION key lights up, and the input level setting for the respective input is shown on the display. For example, if the FUNCTION 3 key was pressed, the (E) in the display shown below flashes, to indicate that the input level for input 3 can be set.

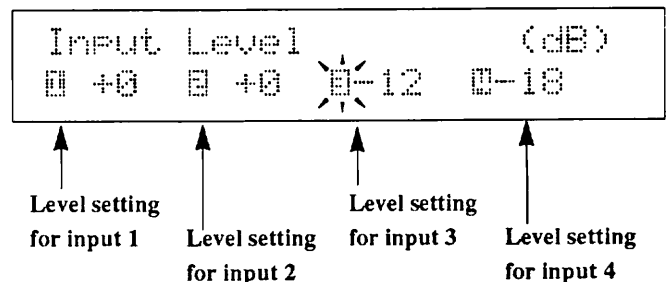
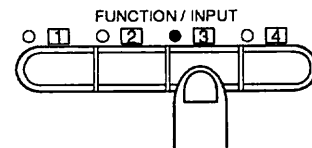

2. Play back the music source and adjust the level with the Dial.

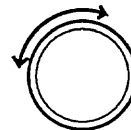

You should adjust the level so that the input level indicators normally do not light up in red.

3. Hold down the FUNCTION 1 key while pressing the FUNCTION 2 key.

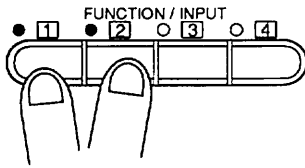

By pressing more than one FUNCTION key at the same time, the input level setting for the respective channels can be linked and adjusted together.

If the FUNCTION 1 key and FUNCTION 2 key were pressed, the indicator of the FUNCTION 2 key also lights up, and the level of input 2 is set to the same value as that for input 1. If the Dial now is turned, the input level setting will affect both inputs. To release the linked condition, press the FUNCTION 1 key or FUNCTION 2 key once more.



If the input from the mixer is a stereo signal, it is convenient to link the two channels for level adjustment.

4. Set the input level for other inputs in the same way.
5. Press the EXIT key.

All FUNCTION key indicators go out, and the unit returns to the Program mode.

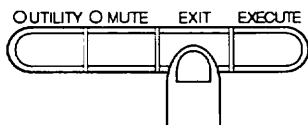

If currently no inputs are linked, pressing the FUNCTION key whose indicator is lit will cause the indicator to go out and the unit will return to the Program mode.

Muting All Effects

The 9200 allows you to turn off (bypass) all effects in one operation. This allows you to check the results of a certain setting or program.

1. In the Program mode, press the MUTE key.

If the unit was in the mute off condition, the indicator of the MUTE key will light up and the indication "Effect MUTE" appears on the display for as long as the key is held down. All effects are now muted (all effect level settings are temporarily set to zero). When the MUTE key is released, the display will revert to its original condition but the "mute on" condition continues.

(Mute off condition)

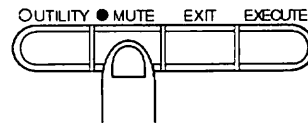
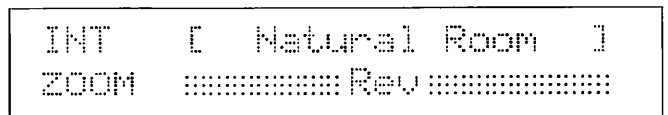

(Mute on condition)

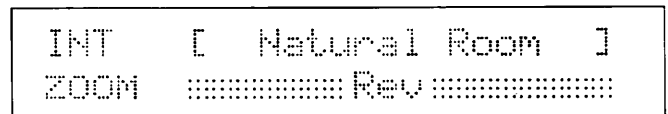
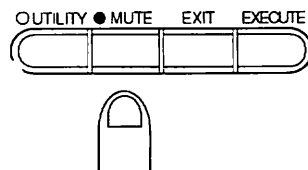
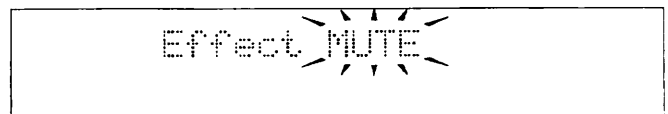

2. Press the MUTE key once more.

If the MUTE key is pressed while the unit is in the "mute on" condition, the indicator of the MUTE key goes out and the indication "Effect ACTIVE" appears on the display for as long as the key is held down. All effect settings are then restored to their original condition.

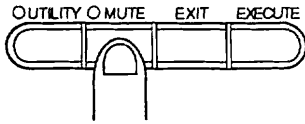

Effect ACTIVE

When the MUTE key is released, the display also reverts to its original condition.



Mute on/off switching can be carried out also in other modes besides the Program mode.

The mute on/off condition is maintained by the unit also when the power is turned off and on again.

Section 3 : Edit Mode

This section explains how to operate the 9200 in Edit mode.

In this mode, you can call up the various effect parameters which make up the programs of the 9200, and you can freely edit the parameters to your desired values.

Program Configuration

Before you attempt to edit any parameters, you should have an understanding of the program architectures and effect modules offered by the 9200. This will make it easier for you to achieve the desired results.

Program Architectures

The 9200 has four different program architectures. A program architecture is characterized by the number of effects it contains and by the input/output signal routing. The available program architectures are as follows.

• Architecture I

Uses one set of stereo inputs and outputs. Only one effect can be used in this program architecture (effect type C in effect module 1).

• Architecture II

Uses two sets of stereo inputs and outputs. Up to two effects can be used in this program architecture (effect type B in effect modules 1 and 2).

• Architecture III

Uses two monaural inputs and outputs and one set of stereo inputs and outputs. Up to three effects can be used in this program architecture (effect type B in effect module 1, effect type A in effect modules 2 and 3).

• Architecture IV

Uses four monaural inputs and outputs. Up to four effects can be used in this program architecture (effect type A in effect modules 1, 2, 3, and 4).

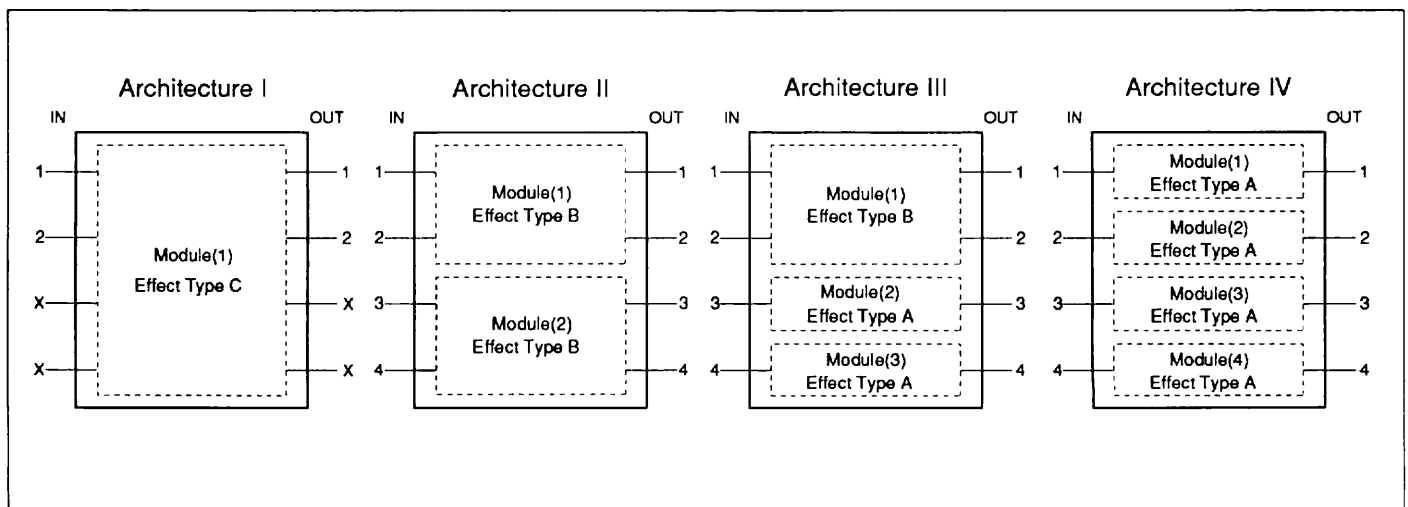

Program Architecture Configuration



NOTE

In the Edit Mode, it is not possible to change the basic characteristics of a program architecture. For example, if you wish to use four effects simultaneously, you have to choose a program from program architecture IV and then edit the parameters of that program.

Effects

The table on the right shows the effects for each effect type.

Effect Link Function

Since the programs of program architectures II through IV use more than one effect module, the effect modules can be connected in a serial or parallel configuration to achieve a complex effect. This is called an effect link . Only one type of effect link can be chosen for each program. It is not possible to choose individual link settings for a certain effect. The following effect link settings are available.

- **Link off (normal setting)**

The INPUT 1 - 4 signal passes the separate effect modules and is supplied to OUTPUT 1 - 4.

- **Serial link**

The INPUT 1 - 4 signal is mixed into two lines which pass the effect modules connected in series before being supplied to OUTPUT 1 and 2. In addition, a signal which has passed only the first effect module is supplied to OUTPUT 3 and 4.

- **Para/Mix (parallel mix) link**

The INPUT 1 and 2 signals are each split into two lines which pass the effect modules connected in parallel before being supplied to OUTPUT 1 - 4. The INPUT 3 and 4 signals are mixed with the INPUT 1 and 2 signals, respectively, and supplied to OUTPUT 1 - 4 after passing a single effect module.

Table Program Architectures and Effects

TYPE A (1in / 1out)	
TYPE A can be used in module 2 / 3 of Architecture III, and module 1 / 2 / 3 / 4 of architecture IV.	
A Rev 1	(Type A Reverb 1)
A Rev 2	(Type A Reverb 2)
A E/Ref	(Type A Early Reflection)
A Echo	(Type A Echo)
A Chors	(Type A Chorus)
A Phase	(Type A Phaser)
A Flang	(Type A Flanger)
A Pitch	(Type A Pitch Shifter)
A Equlz	(Type A Equalizer)
A Gate	(Type A Noise Gate)

TYPE B (2in / 2out)	
TYPE B can be used in module 1 / 2 of architecture II, and module 1 of architecture III.	
B Rev 1	(Type B Reverb 1)
B Rev 2	(Type B Reverb 2)
B Rev 3	(Type B Reverb 3)
B Rev 4	(Type B Reverb 4)
B E/R 1	(Type B Early Reflection 1)
B E/R 2	(Type B Early Reflection 2)
B Echo 1	(Type B Echo 1)
B Echo 2	(Type B Echo 2)
B Chors	(Type B Chorus)
B Phase	(Type B Phaser)
B Flang	(Type B Flanger)
B Pitch	(Type B Pitch Shifter)
B Equlz	(Type B Equalizer)
B Gate	(Type B Noise Gate)

TYPE C (2in / 2out)	
TYPE C can be used only in module 1 of architecture I.	
C Rev 1	(Type C Reverb 1)
C Rev 2	(Type C Reverb 2)
C Rev 3	(Type C Reverb 3)
C Rev 4	(Type C Reverb 4)
C Rev 5	(Type C Reverb 5)
C Rev 6	(Type C Reverb 6)
C Echo	(Type C Echo)
C Chors	(Type C Chorus)

• **Parallel link**

The INPUT 1 and 2 signals are each split into two lines which pass the effect modules connected in parallel before being supplied to OUTPUT 1 - 4. The INPUT 3 and 4 signals are mixed with the INPUT 1 and 2 signals, respectively, and supplied to OUTPUT 3 and 4 only, after passing a single effect module.



- The mixing level is fixed to 1 : 1.
- For programs of architecture 1 (one effect module only), the effect link function cannot be used.
- If the serial, parallel-mix or parallel effect link is used, set the input level parameter for unused inputs to OFF in order to prevent noise.

Architecture II

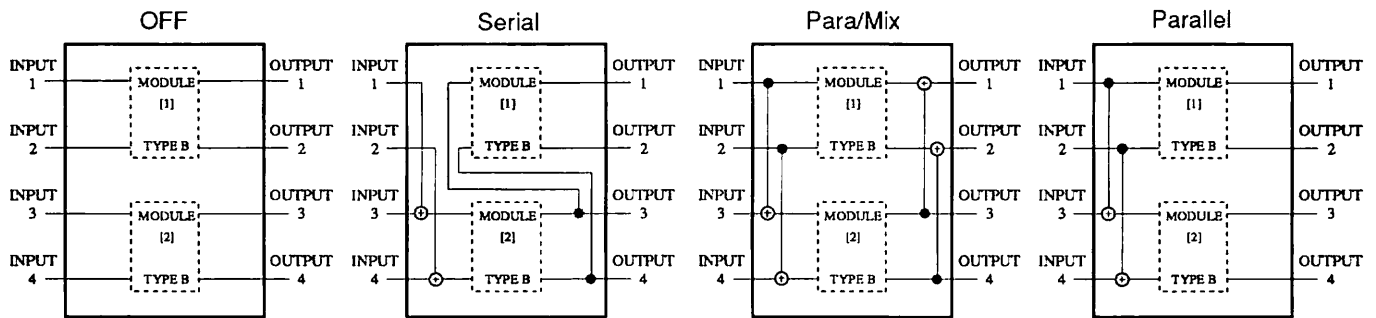

Architecture III

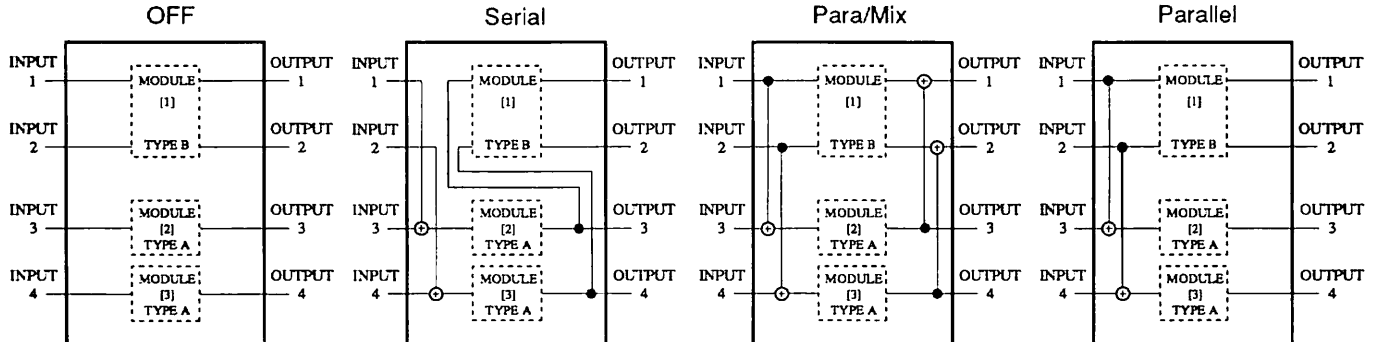

Architecture IV

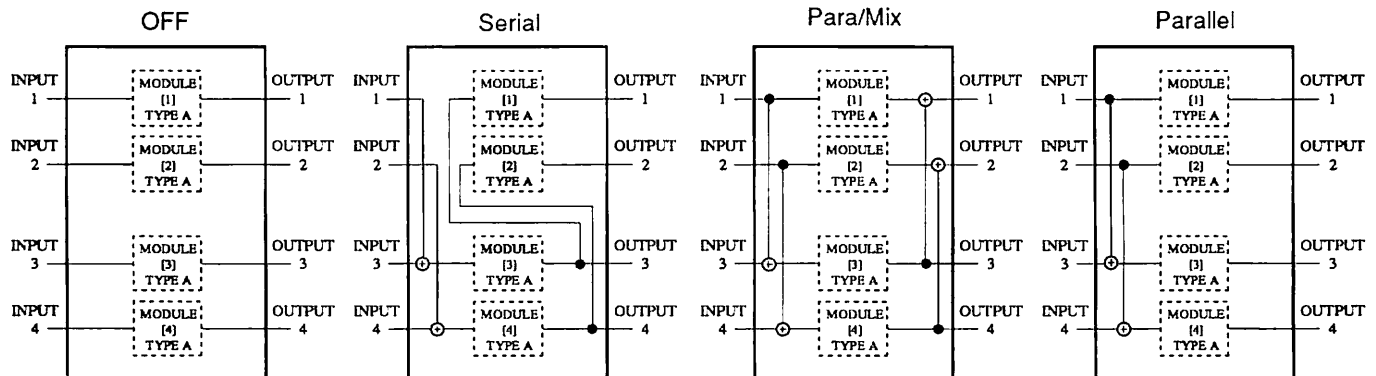

Effect Link Parameters

Pages and Parameters

The setting of parameters for each effect is made up of several pages. One page covers up to four parameters.

To edit the parameters of a program, you call up the relevant page, select the desired parameter, and then alter the numerical values or the setting.



If the currently selected program belongs to program architecture II, you can set the parameters for up to two effect modules. If the program belongs to program architecture III, you can set the parameters for up to three effect modules, and if it belongs to program architecture IV for up to four effect modules.

To Activate the Edit Mode

In the Program mode, press one of the EDIT ▼/▲ keys. (While the key is depressed, the indication "Edit Mode" appears on the display.)

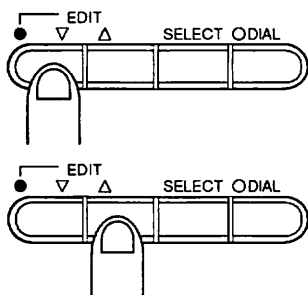

To Cancel the Edit Mode

Press the EXIT key. The unit reverts to the Program mode.

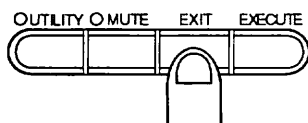

Basic Edit Mode Operation Steps

Selecting a Page or Parameter

1. In the Program mode, press one of the EDIT ▼/▲ keys.

The page with the most recently edited parameter of the current program appears on the display.



The 9200 normally remembers the last edited parameter. However, if you have selected another program in Program mode and then have returned to Edit mode, parameter 1 of page 1 is displayed.

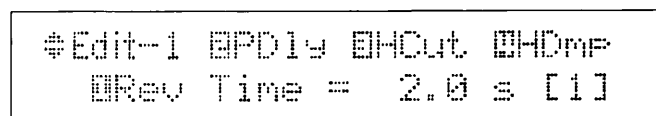
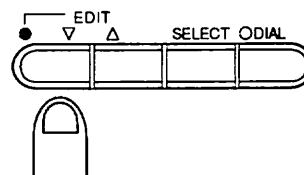
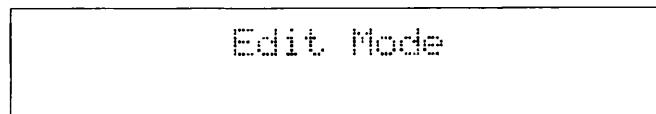
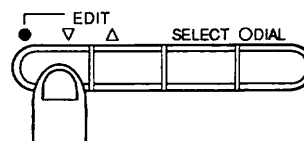

In Edit mode, the following information is shown on the display.

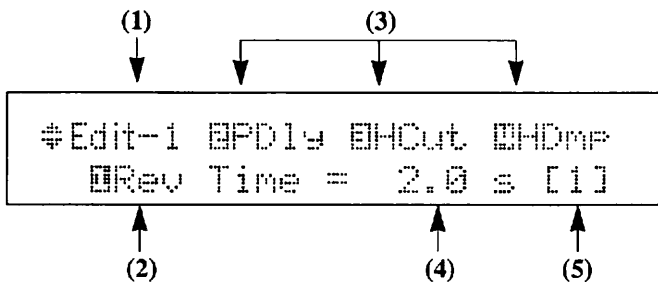

- (1) Currently selected page
- (2) Currently edited parameter
- (3) Other parameters on the current page
- (4) Value of currently edited parameter
- (5) Effect module number

2. Use the EDIT ▼/▲ keys and the FUNCTION 1 - 4 keys to select the page and parameter.

To select a page, use the EDIT ▼/▲ keys, and to move within a page, use the FUNCTION 1 - 4 keys. For example, if you press the FUNCTION 3 key at the first display shown below, the indicator of the FUNCTION 1 key goes out, the indicator of the FUNCTION 3 key comes on, and parameter 3 is selected.

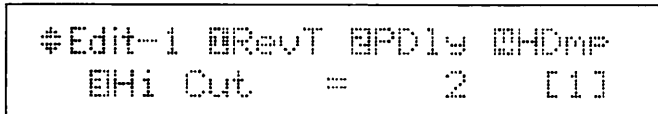
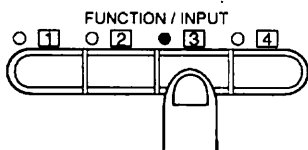
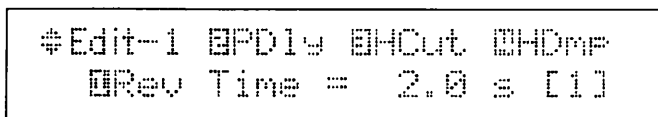

If the EDIT key ▲ is pressed in this condition, parameter 3 of page 2 is displayed.

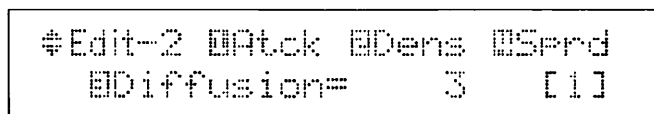
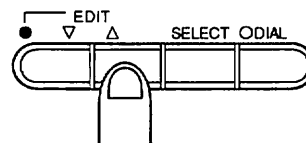
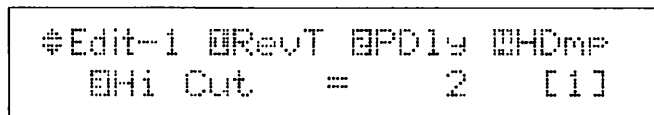

• Pressing and holding a FUNCTION key whose indicator is currently lit will display the name of the currently selected program and the name of the effect module.

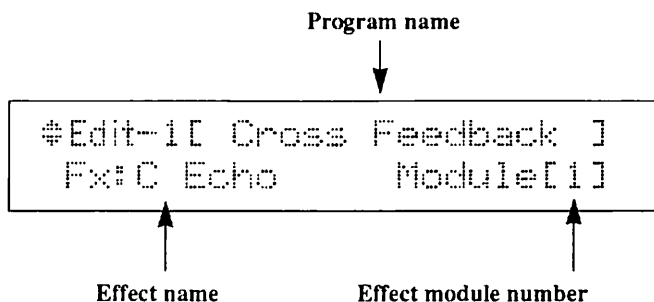

Changing a Parameter Value

When a parameter is selected, turning the Dial will change the parameter value.



Turning the Dial clockwise increases the value and turning it counterclockwise decreases it.



It is possible to select the increment of change caused by one click of the Dial. With each push of the DIAL key, the color of the indicator changes and the setting for the smallest increment changes as follows:

- 1 unit (indicator out)
- 10 units (indicator red)
- 100 units (indicator orange)

Selecting an Effect Module

The above steps are used to edit the parameters of a certain effect module.

If the program belongs to program architecture II (2 effect modules), III (3 effect modules), or IV (4 effect modules), the SELECT key can be used to switch to another effect module.

1. In Program mode, select a program of program architecture II, III, or IV, and activate the Edit mode.

The last edited parameter of the last edited effect module is displayed.



The 9200 remembers the edited parameter for each effect module. However, if you have selected another program in Program mode and then have returned to Edit mode, parameter 1 of page 1 is displayed.

2. Press the SELECT key.

While the key is depressed, the indication "Module Change" appears on the display. Then the next effect module and its number are shown. When the key is released, the last edited parameter of the new effect module is displayed.

```

#Edit-1 BFD1w BHDout BHDmf
  BRev Time = 2.0 s [1]
  
```

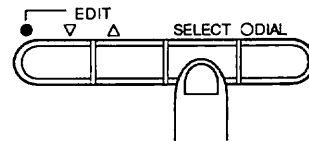

```

Module Changing
Fx:A Rev 1 Module[2]
  
```

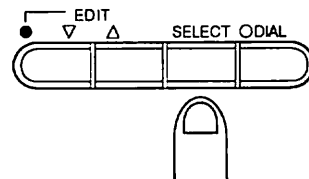

```

#Edit-2 BDens BDffs
  BAttack = 7 % [2]
  
```

Selecting the Effect

For each effect module, the parameter 1 on the last page can be used to select the effect.

1. Press one of the EDIT ▼/▲ keys several times to go to the last page. Then press the FUNCTION 1 key.

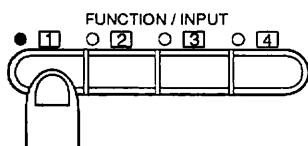

```
#Edit-6 @Name @Dir @Eff
@Fx Select=A Rev 1 [1]
```

2. Use the Dial to select the effect.

```
#Edit-6 @Name @Dir @Eff
@Fx Select=A Rev 1 [1]
```

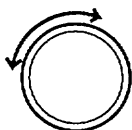

```
#Edit-6 @Name @Dir @Eff
@Fx Select=A Rev 2 [1]
```



Which effects can be selected depends on the range of the effect module. For details, please refer to page 20.

Editing a Program Name

For each effect module, parameter 2 on the last page is the program name, which can also be edited.

1. Press one of the EDIT ▼/▲ keys several times to go to the last page. Then press the FUNCTION 2 key.

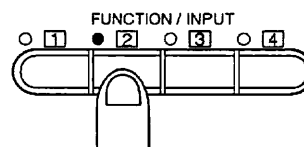

```
#Edit-7 @-Fx- @Dir @Eff
@C_ Real Plate [1]
```

2. Use the SELECT key to move the cursor (....), and select the characters with the Dial.

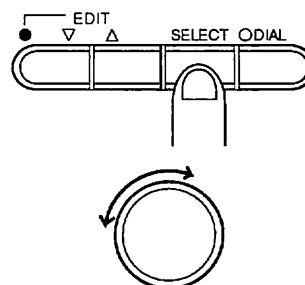

You can move the cursor to the left or right quickly by turning the Dial while the SELECT key is held down. Turning the Dial clockwise moves the cursor to the right and turning the Dial counterclockwise moves the cursor to the left.

A program name can be up to 16 characters long and can include the following letters, numbers, and symbols.

```
0123456789"Space"
ABCDEFGHIJKLMNPOQRSTUVWXYZ"Space"
abcdefghijklmnopqrstuvwxyz"Space"
@!"#$%&'()*+,-./:;<?=[\]^_`{|"Space"
```



You can jump to the beginning of a character category (0/A/a/@) by turning the Dial after pressing the Dial key (the Dial key indicator lit). Press the Dial key again to turn the Dial key indicator off and it reverts to the normal mode.

For programs of architecture II (2 effect modules), III (3 effect modules), or IV (4 effect modules), the last page of any effect module can be used to edit the program name.

Information About Storing Edited Programs

About the Active Buffer

When a program is selected from the preset area or user area, its data are copied into a memory area called the active buffer.

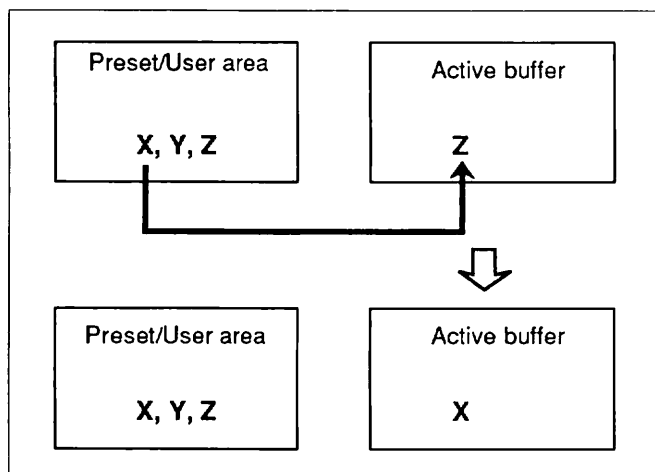

Selecting program X

In the Program mode, the sound as modified by the program in that buffer is heard. Likewise, in the Edit mode, the program that is being edited is the program in the active buffer.

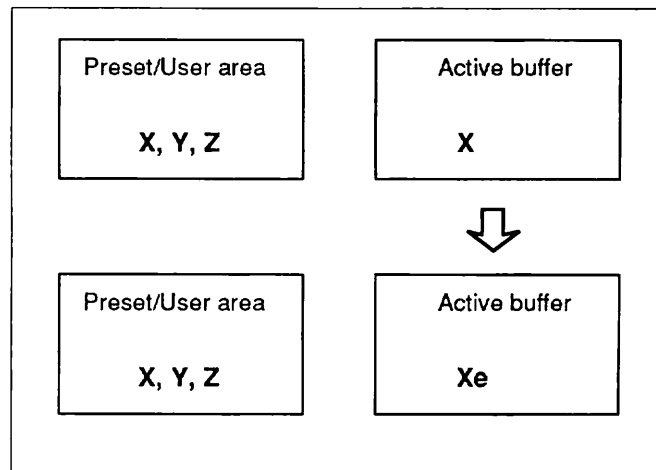

Editing program X

If the edited program is not stored in the user area or on a RAM card, its contents will be lost as soon as another program is selected, i.e. when the data of that program are copied to the active buffer

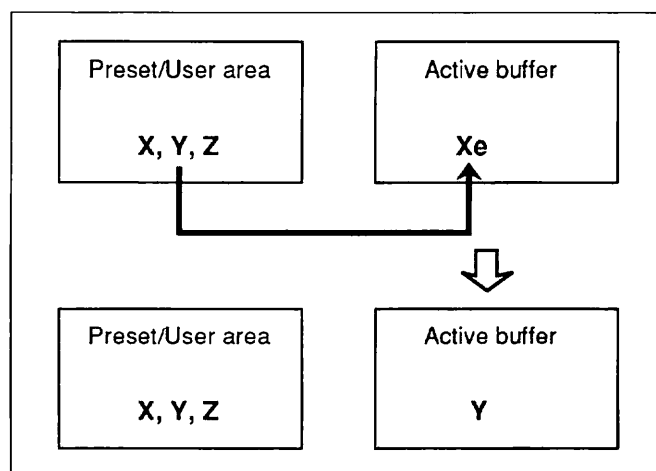

Selecting program Y

If you want to keep an edited program, you must first store it as described on page 37. In order not to lose the results of your editing work, you should get into the habit of frequently storing an edited program, for example whenever you feel that you have made an improvement.

Recall Confirmation

If you have edited a program and returned to the Program mode without saving it, the indication "Recall Sure?" will flash on the display when you press the EXECUTE key.

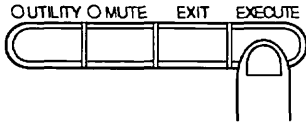

```
INT [ Real, Plate ]
ZOOM  Recall Sure ?
```

If you press the EXECUTE key again, the previously active program will be copied to the active buffer, and the edited program will be lost. The message serves as a safeguard against involuntarily losing the results of a parameter editing session.

If you change your mind, press the EXIT key instead of the EXECUTE key. You will then be returned to the edited program.

Program Change Confirmation

If you have edited a program and returned to the Program mode without saving it, the indication "Change Sure?" will flash on the display when you turn the Dial.

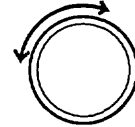

```
INT [ Natural, Room ]
ZOOM  Change Sure ?
```

If you press the EXECUTE key, the previously active program will be copied to the active buffer, and the edited program will be lost. The message serves as a safeguard against involuntarily losing the results of a parameter editing session.

If you change your mind, press the EXIT key. You will then be returned to the edited program.



Section 4 : Edit Utility Mode

In this section, functions such as Compare (listening to the sound before and after changes), Last Edit (recalling the last edited parameters), and Store are explained.

The relationship of the various menus in the Edit Utility mode is shown in the illustration below. By selecting a page on a menu, you move one level down. By pressing the EXIT key, you move one level up.

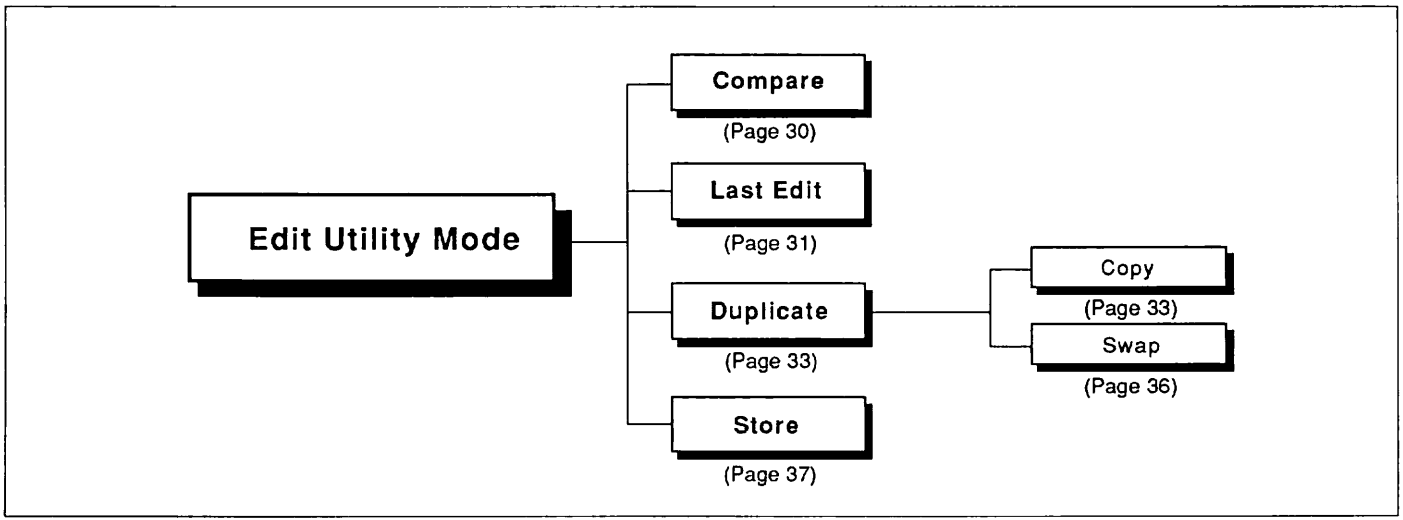

Edit Utility Mode Menus

To Activate the Edit Utility Mode

Press the UTILITY key in the Edit mode. The EDIT indicator and the indicator of the UTILITY key will be lit, indicating that the unit is now in the Edit Utility mode. While the UTILITY key is depressed, the indication "Edit Utility Mode" is shown on the display, and when the key is released, the Edit Utility menu appears.

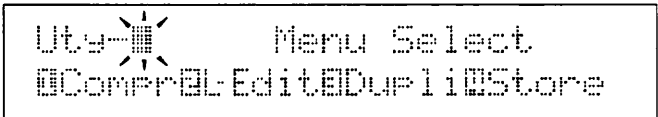
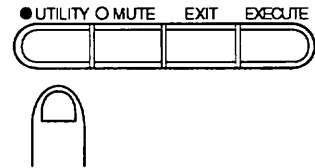

From this menu, you can use the FUNCTION 1 - 4 keys to select one of the following four pages:

- FUNCTION 1 key: Compare
- FUNCTION 2 key: Last Edit
- FUNCTION 3 key: Duplicate (Copy/Swap)
- FUNCTION 4 key: Store

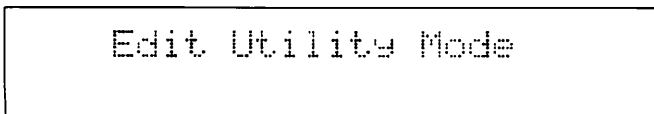
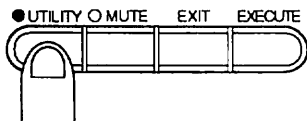
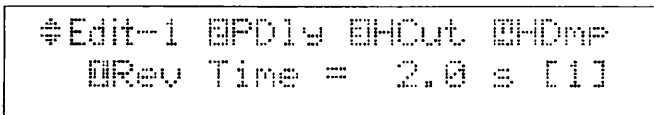

To Cancel the Edit Utility Mode

Press the UTILITY key once more.

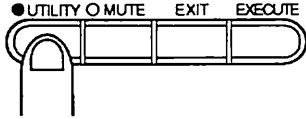

The UTILITY key indicator goes out and the unit reverts to the Edit mode, regardless of which page is currently displayed. Alternatively, you can also press the EXIT key several times to return to the Edit mode.

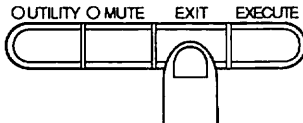

Compare

To call up this page from the Program mode, you press the following keys:

- EDIT ▼/▲ key
- ↓
- UTILITY key
- ↓
- FUNCTION 1 key

In this condition, you can compare the sound before and after editing a program. This is convenient to evaluate the result of parameter changes.

1. Press the FUNCTION 1 key from the initial Edit Utility menu. The display changes as follows.

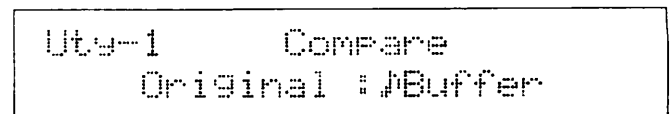
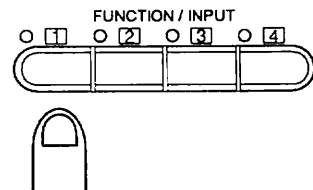
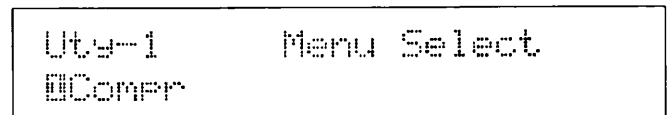
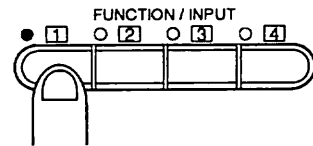
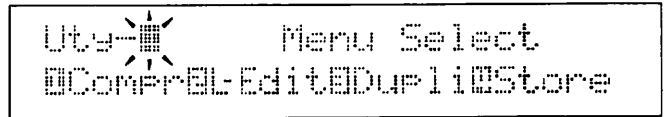

- Use the SELECT key to move the cursor (⏏) and listen either to "Original" (program before editing) or "Buffer" (edited program in buffer).

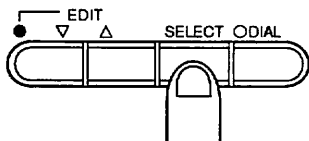

```

Uty-1      Compare
Original : Buffer
  
```

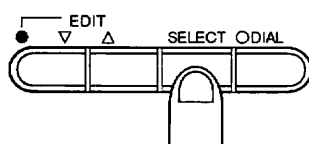

```

Uty-1      Compare
Original : Buffer
  
```

- To terminate the Compare function, press the UTILITY key again.

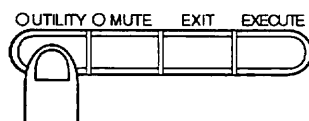

The unit reverts to the Edit mode.

Last Edit

To call up this page from the Program mode, you press the following keys:

- EDIT ▼/▲ key
- ↓
- UTILITY key
- ↓
- FUNCTION 2 key

The 9200 lets you freely edit any chosen program, for example to fit the mood of a performance. However, when putting the final touches on program, calling up the same two or three parameters repeatedly using the regular procedure is quite tedious.

The Last Edit page is very convenient in such an instance, because it always remembers the last three edited parameters before the current one. Simply by using the FUNCTION key 1 - 4 on this page, you can select the desired parameter for renewed editing. It does not matter if the parameters were from various different pages or if you have changed modules in the meantime. The Last Page makes even complicated editing operations a snap.

The Last Edit page information is stored in the user area as part of the program data.



If the effect type used by the currently edited module was changed, all parameters of that module are replaced. Therefore the previously edited parameters in that module are not remembered and cannot be recalled with the Last Edit page.

1. Press the **FUNCTION 2** key from the initial Edit Utility menu. The display changes as follows.

```

Uty-2  Menu Select
@ComPr@L>Edit@Dupli@Store
  
```

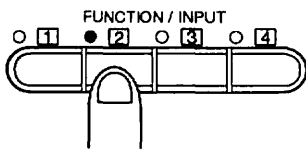

```

Uty-2  Menu Select
@L>Edit
  
```

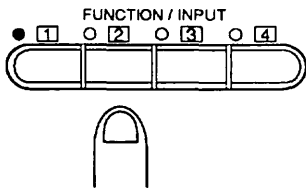

```

Uty-2  Last Edit
@Hi Out = 6 [2]
  
```

2. Use one of the **FUNCTION 1 - 4** keys to select the desired parameter, and turn the Dial to adjust the value.

```

Uty-2  Last Edit
@Hi Out = 6 [2]
  
```

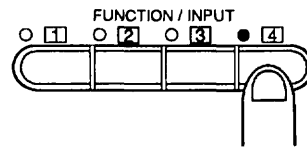

```

Uty-2  Last Edit
@Rev Time = 2.9 s [1]
  
```

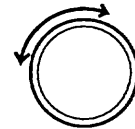

```

Uty-2  Last Edit
@Rev Time = 2.8 s [1]
  
```

3. To terminate the Last Edit function, press the **UTILITY** key again. The unit reverts to the Edit mode.

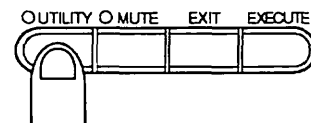

As during normal editing, you can select the increment by which the Dial changes the parameter value (refer to page 24).

Duplicate

To call up this page from the Program mode, you press the following keys:

- EDIT ▼/▲ key
↓
- UTILITY key
↓
- FUNCTION 3 key

This page lets you select "Copy" function to copy a parameter setting to another or "Swap" function to swap parameter settings.

Copy helps you to make it easier to use a parameter setting out of the preset programs or so for your new program. With Swap, you can exchange the two effects for input and output with each other without re-connection, for instance.

Copy

To call up this page from the Program mode, you press the following keys:

- EDIT ▼/▲ key
↓
- UTILITY key
↓
- FUNCTION 3 key
↓
- FUNCTION 1 key

This function lets you copy an effect of the same effect type (A, B, or C) as used by the currently edited effect module into any desired memory area (including the active buffer).

Since the effect is copied with all its parameter settings, you can fully replicate an effect in the active buffer or used by another program (provided the effect is of the same effect type).



Only the parameters of the effect are copied, not any effect link settings or the program name.



The available copy source depends on the currently edited effect module.

- *Architecture I, module 1*
The effect type C can be used. An effect can be copied from any program of architecture I.

- *Architecture II, module 1*
The effect type B can be used. An effect can be copied from module 2 in the active buffer, from module 1 or 2 of any program of architecture II, or from module 1 of any program of architecture III.

- **Architecture III, module 1**

The effect type B can be used. An effect can be copied from module 1 or 2 of any program of architecture II, or from module 1 of any program of architecture III.

- **Architecture III, module 2**

The effect type A can be used. An effect can be copied from module 3 in the active buffer, from module 2 or 3 of any program of architecture III, or from module 1, 2, 3, or 4 of any program of architecture IV.

- **Architecture IV, module 3**

The effect type A can be used. An effect can be copied from module 1, 2 or 4 in the active buffer, from module 2 or 3 of any program of architecture III, or from module 1, 2, 3, or 4 of any program of architecture IV.

1. Press the **FUNCTION 3** key from the initial Edit Utility menu.

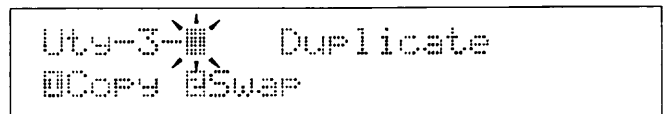
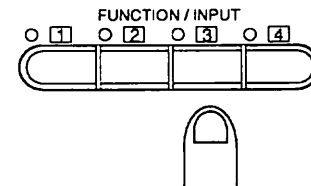
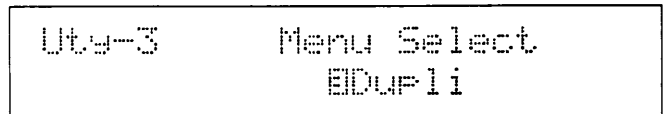
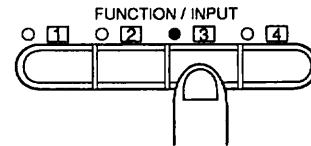
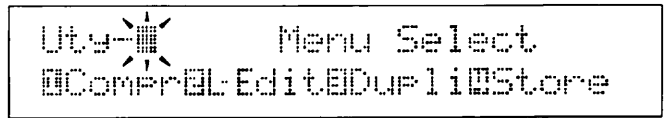

2. Press the **FUNCTION 1** key and select **Copy**.

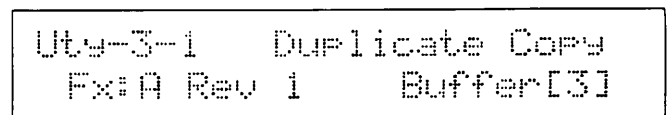
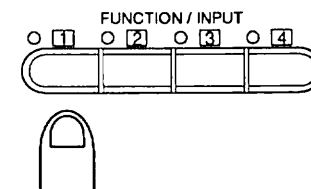
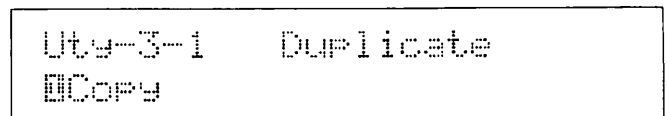
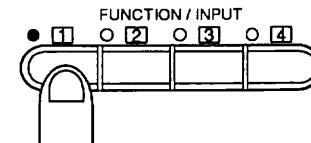

- Turn the Dial to select the copy source area, program number and module number.

```
Uty-3-1 Duplicate Copy
Fx:A Rev 1 Buffer[3]
```

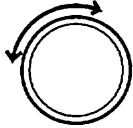

```
Uty-3-1 Duplicate Copy
Fx:A Rev 2 Buffer[4]
```

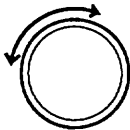

```
Uty-3-1 Duplicate Copy
Fx:A E/Ref INT/U01[1]
```



NOTE

When module 3 of architecture IV was selected as a copy source, turning the Dial by one click to the right will select module 4 in the active buffer as copy source. Turning the Dial further right will switch to other memory areas and modules available as copy source.

Turning the Dial by one click to the left will select the current module in the active buffer as copy source, and turning the Dial further left will switch to module 1 in the active buffer, and then to other memory areas and modules available as copy source.

- Press the EXECUTE key.

The following verification message appears.

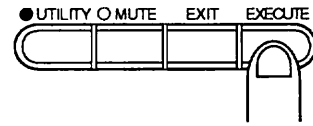

```
Uty-3-1 Sure ?
Fx:A E/Ref INT/U01[1]
```

When the EXECUTE key is pressed once more, the selected effect and its parameter settings are copied to the currently edited module.

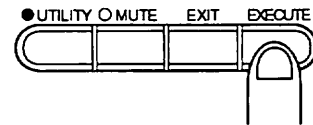

```
Uty-3-1 Completed
Fx:A E/Ref INT/U01[1]
```

- If you change your mind, press the EXIT key while the "Sure?" message is displayed. The Copy operation is canceled and the unit reverts to the previous display.



When wishing to change the copy target effect module, you can temporarily leave the Edit Utility mode and select another module.

Swap

To call up this page from the Program mode, you press the following keys:

- EDIT ▼/▲ key
- ↓
- UTILITY key
- ↓
- FUNCTION 3 key
- ↓
- FUNCTION 2 key

This page lets you swap effect modules in the currently edited program as long as both are of the same effect type (A, B).



For example, if you create a program in architecture II, where effect module 1 is loaded with B Rev 3, and effect module 2 with B Equalizer, and they are linked in series, the signal passes first through the EQ and then the reverb. You can use the Swap function to change the order so that effect module 1 contains the EQ and effect module 2 the reverb. Now the signal passes first through the reverb and then the EQ.

The available swap source depends on the currently edited effect module:

- With programs of architecture I, swapping cannot be carried out.
- With module 1 of architecture II, swapping is limited to module 2.
- With module 1 of architecture III, swapping cannot be carried out. With module 2, swapping is limited to module 3.
- With module 3 of architecture IV, swapping can be carried out with module 1, 2, or 4.

1. Press the FUNCTION 3 key from the initial Edit Utility menu.

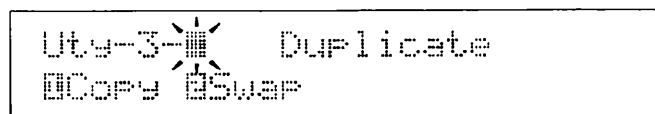
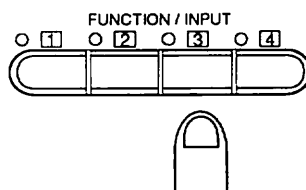
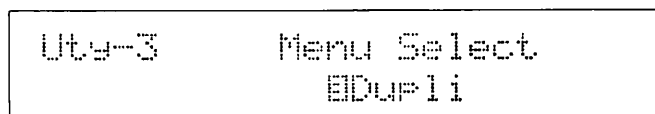
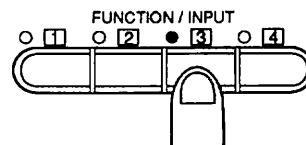
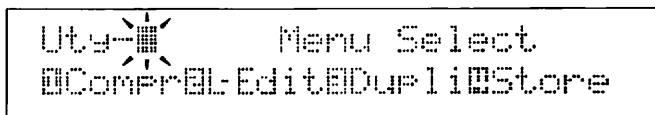

2. Press the FUNCTION 2 key and select Swap.

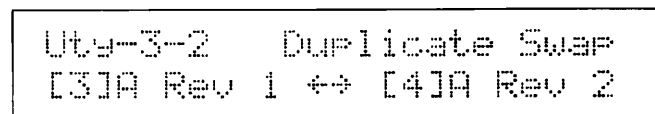
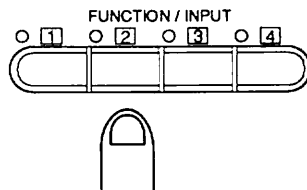
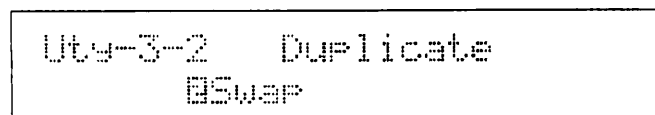
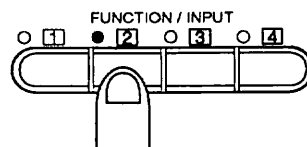

3. Turn the Dial to select the swap source module number.

```
Uty-3-2 Duplicate Swap
[3]A Rev 1 ↔ [4]A Rev 2
```

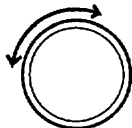

```
Uty-3-2 Duplicate Swap
[3]A Rev 1 ↔ [1]A E/Ref
```

When the EXECUTE key is pressed, the effect in the currently edited module is replaced with the effect selected as swap source. All parameter settings are also replaced.

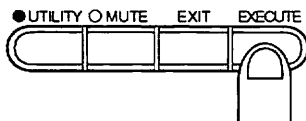

```
Uty-3-2 Duplicate Swap
[3]A E/Ref ↔ [1]A Rev 1
```



When wishing to change the swap target effect module, you can temporarily leave the Edit Utility mode and select another module.

Store

To call up this page from the Program mode, you press the following keys:

- EDIT ▼/▲ key
↓
- UTILITY key
↓
- FUNCTION 4 key

This function serves to store the currently selected program in the user area or on a RAM card.

Storing a Program in the Same Location

1. Press the FUNCTION 4 key from the initial Edit Utility menu.

```
Uty-4 Menu Select
[ConFrBL:Edit]Dupli[Store]
```

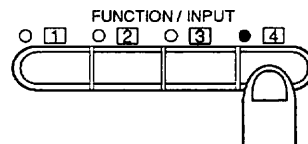

```
Uty-4 Menu Select
[Store]
```

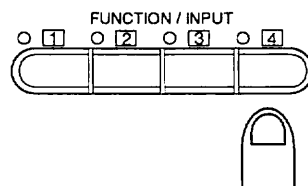

```
Uty-4 [ Cross Feedback ]
Store Buffer → INT/USB
```

The currently selected program number flashes, which indicates that this number is being offered as the store target.

2. Press the EXECUTE key.

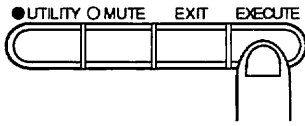

The following verification message appears.

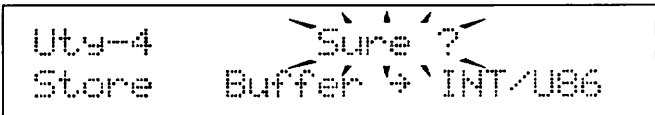

When a program is stored, the previous program at that number is cleared. The confirmation message serves as a safeguard against involuntarily overwriting a program.

When the EXECUTE key is pressed once more, the selected program is stored at the same program number. The following indication briefly appears on the display, and then the unit reverts to the initial Store page.

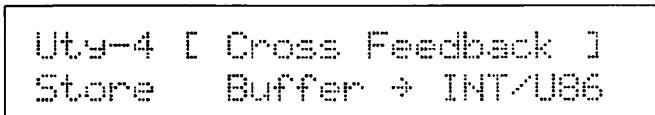
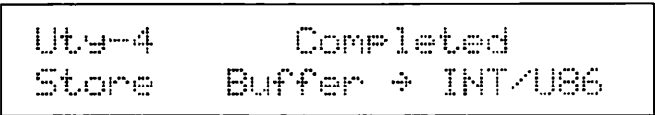
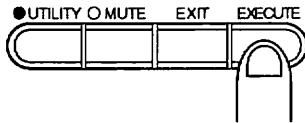

NOTE

If the Store page is activated while a program from the preset area or a ROM card is selected, the display changes as follows.

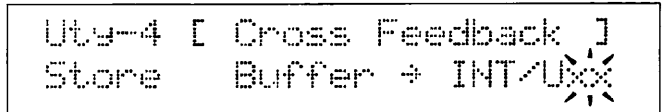

Since a program cannot be stored in the preset area or on a ROM card, the 9200 prompts you to select a different store location. Turn the Dial to select a Store area and number, and press the EXECUTE key twice. If you press the EXECUTE key without first selecting a Store location, the following error message is displayed.

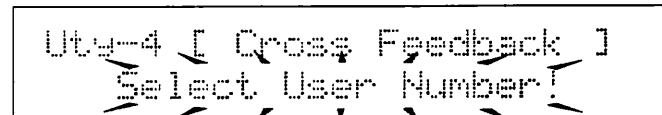

3. If you change your mind, press the EXIT key while the "Sure?" message is displayed. The Store operation is canceled and the unit reverts to the previous display.

Storing a Program in a Different Location

It is also possible to store a program in a different area and under a different number, by selecting the area and number with the Dial after calling up the Store page.

1. Press the FUNCTION 4 key from the initial Edit Utility menu.

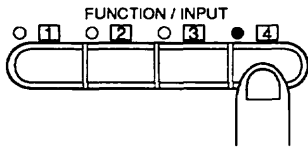

```

Uty-4 [ Cross Feedback ]
Store  Buffer + INT/U086
    
```

2. Turn the Dial to select a Store area and number.

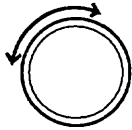

```

Uty-4 [ Natural Room ]
Store  Buffer + INT/U009
    
```



NOTE

If you want to store the program on a new RAM card, you have to format (initialize) the card first. Please refer to page 52 for instructions on how to format a RAM card.

3. Press the EXECUTE key.

The following verification message appears.

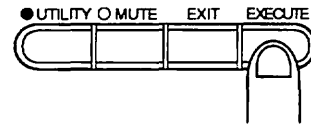

```

Uty-4          Sure ?
Store  Buffer + INT/U009
    
```

When the EXECUTE key is pressed again, the program is stored in the currently selected location.

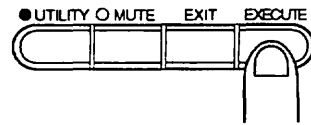

```

Uty-4          Completed
Store  Buffer + INT/U009
    
```

4. If you press the EXIT key while the "Sure?" message is displayed, the Store operation is canceled and the unit reverts to the previous display.

Verifying a Program at a Store Location

You can check which program is stored at a certain location by calling it up and listening to it.

1. Press the FUNCTION 4 key from the initial Edit Utility menu.

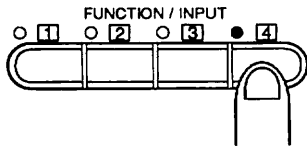

```
Uty-4 [ Cross Feedback ]
Store  Buffer → INT/U86
```

2. Turn the Dial to select a Store area and number.

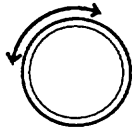

```
Uty-4 [ Natural Room ]
Store  Buffer → INT/U09
```

3. Press the SELECT key.

The note symbol at the program name flashes, and the program temporarily becomes active (it now modifies the output sound).

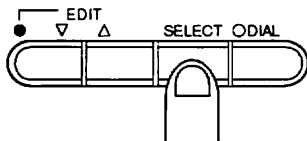

```
Uty-4 [ Natural Room ]
Store  Buffer → INT/U09
```

4. Press the SELECT key again to turn the program off and revert to the previous display.

Section 5 : Utility Mode

In this section, general functions of the 9200 such as MIDI settings, storing programs, etc. are explained.

The relationship of the various menus in the Utility mode is shown in the illustration below. By selecting a page on a menu, you move one level down. By pressing the EXIT key, you move one level up.

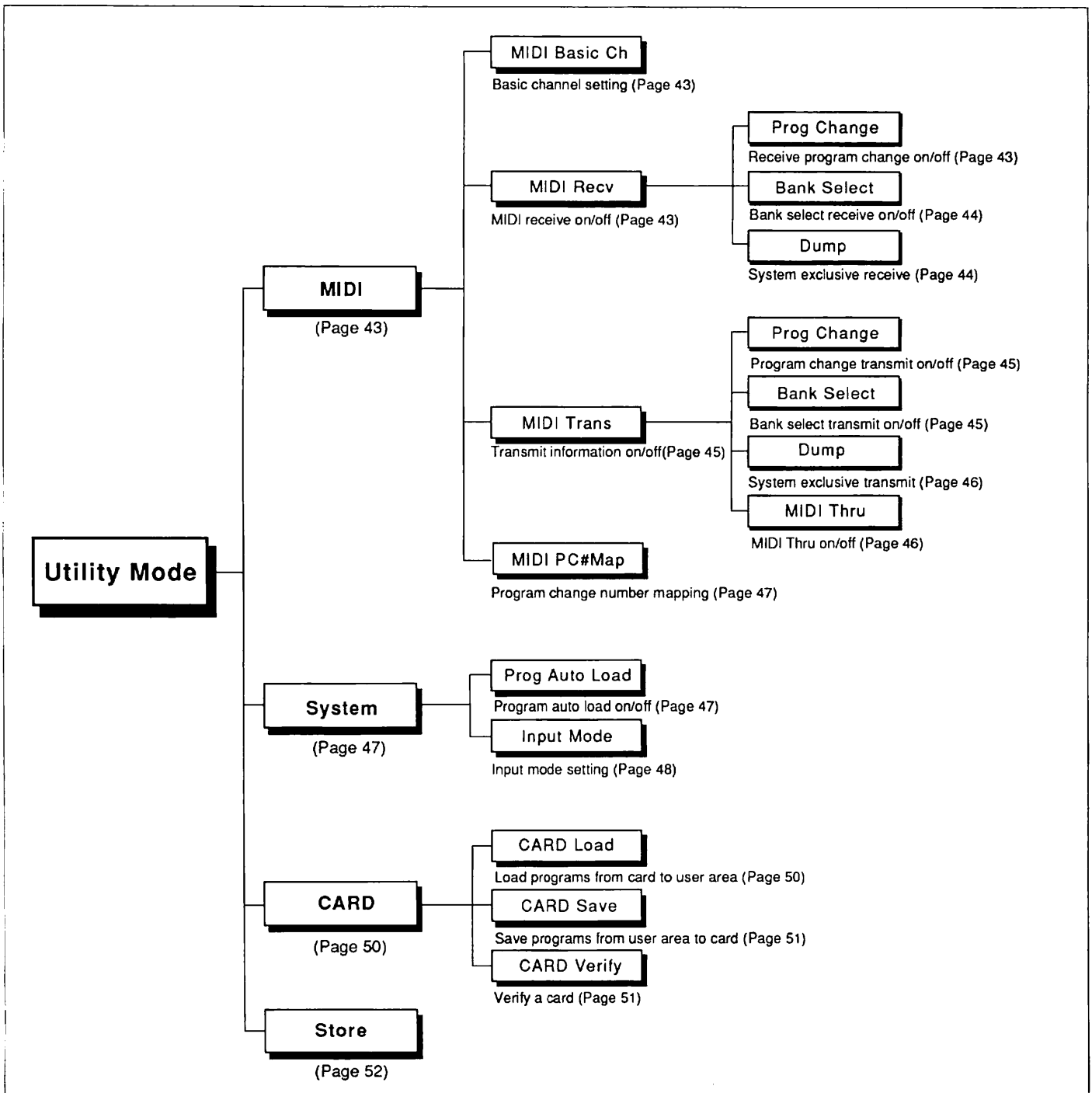

Utility Mode Menus

To Activate the Utility Mode

Press the UTILITY key in the Program mode. The first menu page is displayed.

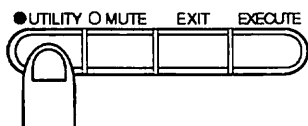

Utility Mode

From this menu, you can use the FUNCTION 1 - 4 keys to select one of the following four pages:

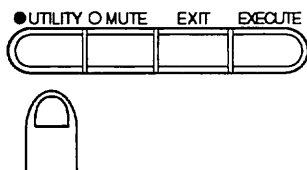

Uty-Menu Select
MIDI SystemCARD Store

- FUNCTION 1 key : MIDI
- FUNCTION 2 key : System
- FUNCTION 3 key : Card
- FUNCTION 4 key : Store

To Cancel the Utility Mode

Press the UTILITY key once more.

The indicator of the key goes out and the unit reverts to the Program mode, regardless of which page is currently displayed.

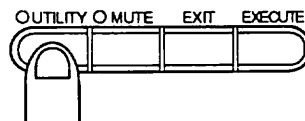

Alternatively, you can also press the EXIT key several times to return to the Program mode.

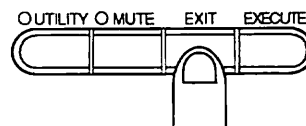

MIDI

This page allows you to set the basic channel and make other MIDI settings.

After you press the FUNCTION 1 key at the Utility mode main menu, the following menu is displayed, and you can choose one of the four pages with the FUNCTION 1 - 4 keys.

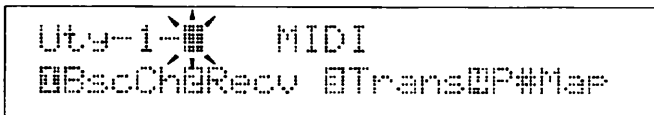

1 Basic channel setting (MIDI Basic Ch)

To call up this page from the Program mode, you press the following keys:

- UTILITY key
↓
- FUNCTION 1 key
↓
- FUNCTION 1 key

This page lets you use the Dial to select the basic channel on which the 9200 will receive MIDI program change and band select information.

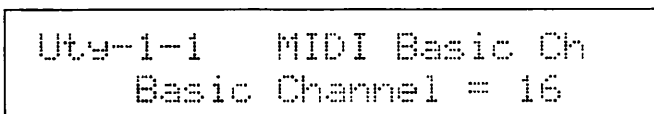

Turn the Dial to select the channel. The available settings are ALL and 1 through 16. If ALL is selected, information is received on all MIDI channels.



When wishing to remotely control the 9200 from an external MIDI component, set the send channel of the MIDI component and the basic channel of the 9200 to the same number, or use the ALL setting.

2 MIDI receive on/off (MIDI Recv)

To call up this page from the Program mode, you press the following keys:

- UTILITY key
↓
- FUNCTION 1 key
↓
- FUNCTION 2 key

This page lets you select whether the 9200 will receive MIDI information or not. The page has three submenus (2-1 to 2-3).

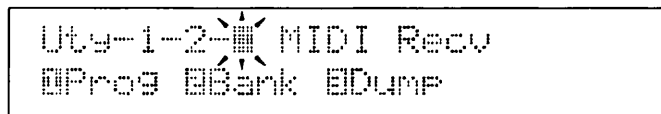

Use the FUNCTION 1 - 3 keys to select the type of MIDI data, and use the Dial to set them to ON or OFF.

2-1 Receive program change on/off (MIDI Recv Prog Change)

To call up this page from the Program mode, you press the following keys:

- UTILITY key
↓
- FUNCTION 1 key
↓
- FUNCTION 2 key
↓
- FUNCTION 1 key

This page lets you select whether the 9200 will receive MIDI program change information or not. Use the Dial to select ON or OFF.

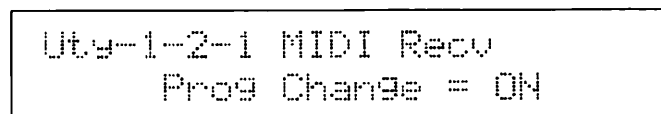

2-2 Bank select receive on/off (MIDI Recv Bank Select)

To call up this page from the Program mode, you press the following keys:

- UTILITY key
- ↓
- FUNCTION 1 key
- ↓
- FUNCTION 2 key
- ↓
- FUNCTION 2 key

This page lets you select whether the 9200 will receive MIDI bank select information or not. Use the Dial to select ON or OFF. When this item is set to ON, you can use the bank select command to switch program areas.

```
Uty-1-2-2 MIDI Recv
      Bank Select = ON
```



*The bank select command can handle 128 or more programs.
For details, please refer to the MIDI implementation.*

2-3 System exclusive receive (MIDI Recv Dump)

To call up this page from the Program mode, you press the following keys:

- UTILITY key
- ↓
- FUNCTION 1 key
- ↓
- FUNCTION 2 key
- ↓
- FUNCTION 3 key

This page lets you receive bulk data (9200 settings and program data) from a MIDI data file or computer.

```
Uty-1-2-3 MIDI Recv
      Dump      Waiting
```

When the unit has started receiving system exclusive data, the display changes as follows.

```
Uty-1-2-3 MIDI Recv
      Dump      Receiving
```

After all system exclusive data have been received, the display reverts to the original condition.

3 Transmit information on/off (MIDI Trans)

To call up this page from the Program mode, you press the following keys:

- UTILITY key
- ↓
- FUNCTION 1 key
- ↓
- FUNCTION 3 key

This page lets you select whether the 9200 will transmit MIDI information or not. The page has four submenus (3-1 to 3-4).

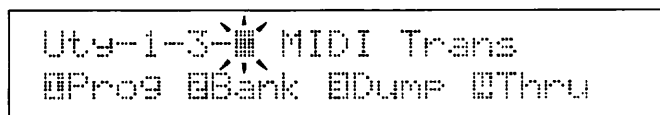

Use the FUNCTION 1 - 4 keys to select the type of MIDI data, and use the Dial to set them to ON or OFF.

3-1 Program change transmit on/off (MIDI Trans Prog Change)

To call up this page from the Program mode, you press the following keys:

- UTILITY key
- ↓
- FUNCTION 1 key
- ↓
- FUNCTION 3 key
- ↓
- FUNCTION 1 key

This page lets you select whether the 9200 will transmit MIDI program change information or not. Use the Dial to select ON or OFF.

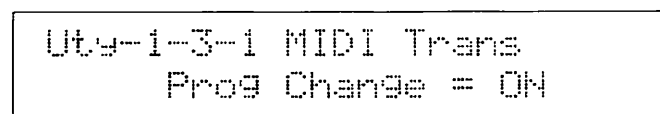

3-2 Bank select transmit on/off (MIDI Trans Bank Select)

To call up this page from the Program mode, you press the following keys:

- UTILITY key
- ↓
- FUNCTION 1 key
- ↓
- FUNCTION 3 key
- ↓
- FUNCTION 2 key

This page lets you select whether the 9200 will transmit a MIDI bank select signal when the controls of the 9200 were used to switch between the user area and the RAM card. Use the Dial to select ON or OFF.

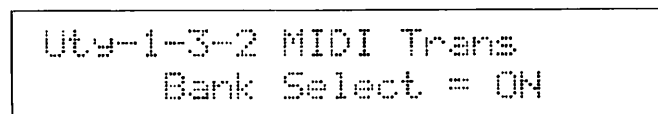

3-3 System exclusive transmit (MIDI Trans Dump)

To call up this page from the Program mode, you press the following keys:

- UTILITY key
- ↓
- FUNCTION 1 key
- ↓
- FUNCTION 3 key
- ↓
- FUNCTION 3 key

This page lets you transmit bulk data to other MIDI equipment. Use the Dial to select which data to send.

```
Uty-1-3-3 MIDI Trans
Dump      Data = Buffer
```

- Buffer : Data currently in active buffer
- INT : All program data in internal user area
- CARD : All program data on RAM card (when RAM card is inserted)
- UtyData : All utility mode settings

After selecting the data, press the EXECUTE key. The display changes as follows, and the unit starts to transmit system exclusive data.

```
Uty-1-3-3 MIDI Trans
      Transmitting
```

After all system exclusive data have been sent, the display reverts to the original condition.

3-4 MIDI Thru on/off (MIDI Trans MIDI Thru)

To call up this page from the Program mode, you press the following keys:

- UTILITY key
- ↓
- FUNCTION 1 key
- ↓
- FUNCTION 3 key
- ↓
- FUNCTION 4 key

This page determines the function of the MIDI OUT jack. Use the Dial to select ON or OFF.

```
Uty-1-3-4 MIDI Trans
      MIDI Thru = ON
```

•MIDI Thru ON:

The MIDI OUT jack functions as MIDI THRU jack. All received MIDI data are routed through the 9200 without alteration or addition.

•MIDI Thru OFF:

Program change or system exclusive data from the 9200 are output by the MIDI OUT jack.



If MIDI Thru is set to ON, no program change or bank select data from the 9200 will be transmitted, even if these items are set to ON.

4 Program change number mapping (MIDI PC # Map)

To call up this page from the Program mode, you press the following keys:

- UTILITY key
↓
- FUNCTION 1 key
↓
- FUNCTION 4 key

This function lets you assign programs of the 9200 to the MIDI program change numbers 1 - 128, to facilitate remote control via external equipment. Use the SELECT key to move the cursor () to the desired item, and use the Dial to set the number.

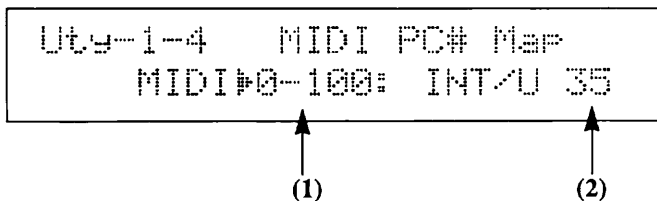

(1) MIDI bank number and program number:

Selects the MIDI bank number and program number to which a 9200 program is assigned.

Available bank numbers are 0 (user area) or 1 (RAM card), each with program numbers from 1 to 128.

Turning the Dial will continuously change the numbers from 0-1 to 0-128. If a RAM card is inserted, the range 1-1 to 1-128 is covered next.

(2) Program number:

Selects the program number of the 9200.

If the MIDI bank number is 0, the available range is INT/U 01 - 99 (user area 1 - 99). To make the unit disregard program change information, use the setting INT/U xx. If the MIDI bank number is 1, the available range is CRD/U 01 - 99 (RAM card area 1 - 99). To make the unit disregard program change information, use the setting CRD/U xx.

System

This page lets you select general system settings, such as the program loading method and input mode.

After you press the FUNCTION 2 key at the Utility mode main menu, the following menu is displayed, and you can choose one of the two pages with the FUNCTION 1 - 2 keys.

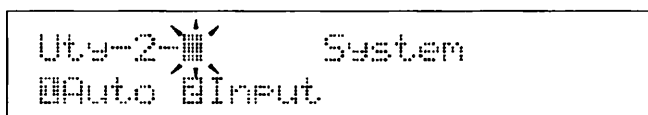

1 Program auto load on/off (Prog Auto Load)

To call up this page from the Program mode, you press the following keys:

- UTILITY key
↓
- FUNCTION 2 key
↓
- FUNCTION 1 key

This page lets you turn automatic program loading on or off.

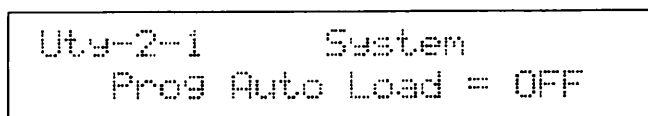

• Auto Load OFF:

When the Dial is turned to change program numbers, the next program is loaded only after pressing the EXECUTE key.

• Auto Load ON:

When the Dial is turned to change program numbers, the next program is loaded immediately.



The auto load function is best set to ON for checking or editing the sound of programs, and to OFF when switching programs during a performance or recording session.

2 Input mode setting (Input Mode)

To call up this page from the Program mode, you press the following keys:

- UTILITY key
↓
- FUNCTION 2 key
↓
- FUNCTION 2 key

This page lets you choose whether to use the 9200 with a monaural or stereo input. Use the Dial to select either MONO or STEREO.

```
Uty-2-2      System
      Input Mode = STEREO
```

• Input mode MONO (MONO indicator lit)

Architecture I:

Only the INPUT 1 signal is active. The signal is split into two lines and fed to the effect module.

Architectures II/III/IV:

Only the INPUT 1 and 3 signals are active. The signals are each split into two lines and fed to the effect modules.

• Input mode STEREO (STEREO indicator lit)

Architecture I:

Only the INPUT 1 and 2 signals are active. The signals are fed directly to the effect module.

Architectures II/III/IV:

All INPUT 1 - 4 signals are active. The signals are fed directly to the effect module.

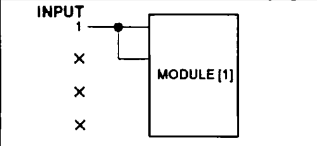
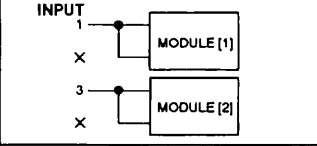
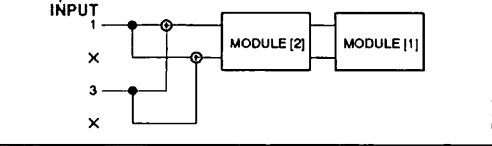
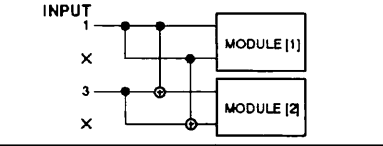
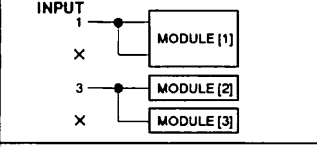
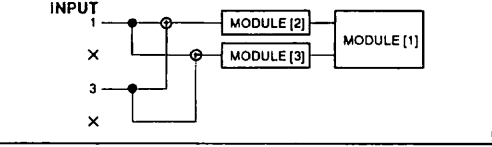
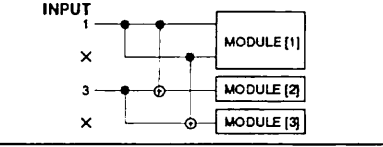
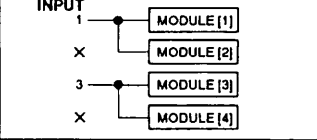
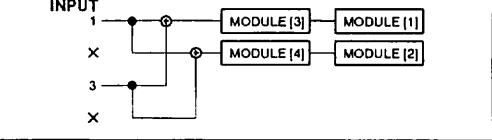
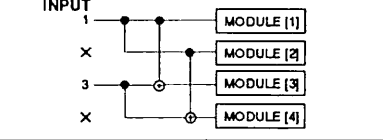

If the serial, parallel-mix or parallel effect link is used, set the input level parameter for unused inputs to OFF in order to prevent noise.

Input mode : MONO			
Architecture	Fx Link		
	OFF	Serial	Para / Mix, Parallel
I			
II			
III			
IV			

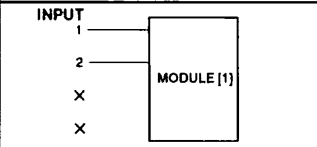
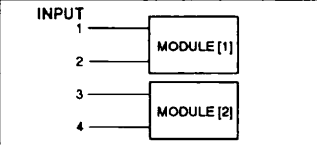
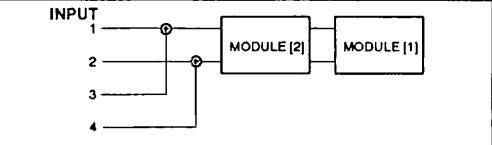
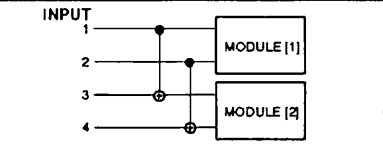
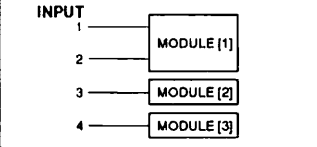
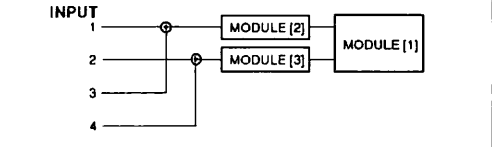
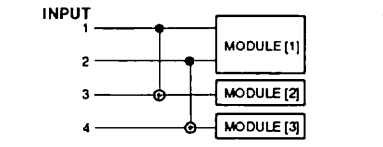
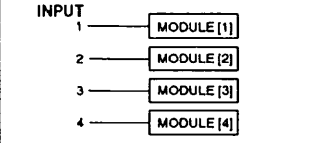
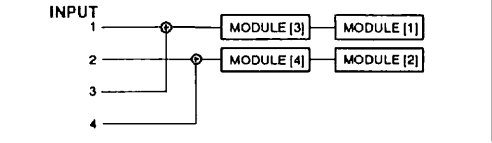
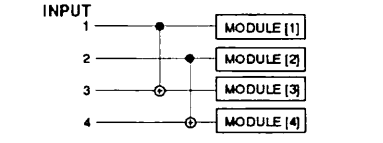
Input mode : STEREO			
Architecture	Fx Link		
	OFF	Serial	Para / Mix, Parallel
I			
II			
III			
IV			

Input mode setting

CARD

This page lets you read all the programs on a ROM card or RAM card into the user area, or store all the programs in the user area on a RAM card.

After you press the FUNCTION 3 key at the Utility mode main menu, the following menu is displayed, and you can choose one of the three pages with the FUNCTION 1 - 3 keys.

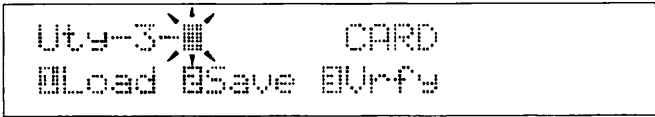

NOTE

If this page is called while no card is inserted in the card slot, the indication "CARD Error" appears on the display.

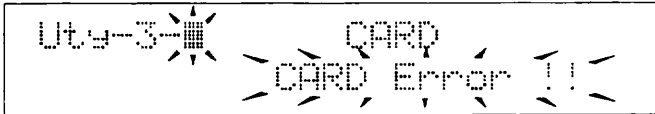

If a RAM card is inserted which was not formatted, and an item from this page is selected (for example "CARD Load"), the following warning is displayed.

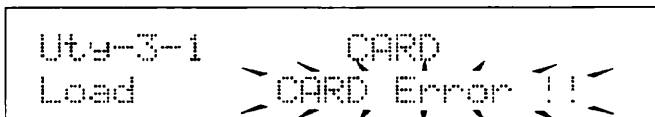

For details on formatting a RAM card, please refer to page 52.

1 Load programs from card to user area (CARD Load)

To call up this page from the Program mode, you press the following keys:

- UTILITY key
↓
- FUNCTION 3 key
↓
- FUNCTION 1 key

This page lets you load all programs on a ROM card or RAM card into the user area.

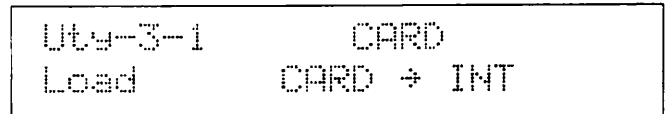

When the EXECUTE key is pressed, the verification message "Sure?" appears.

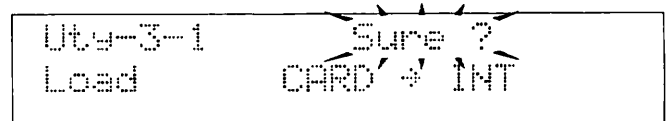

When the EXECUTE key is pressed once more, all programs on the card inserted in the card slot (ROM card or RAM card) are loaded into the user area. After all programs have been transferred, the message "Completed" is shown, and the display reverts to the initial screen.

2 Save programs from user area to card (CARD Save)

To call up this page from the Program mode, you press the following keys:

- UTILITY key
↓
- FUNCTION 3 key
↓
- FUNCTION 2 key

This page lets you save all programs in the user area on a RAM card.

```
Uty-3-2      CARD
Save         INT → CARD
```

When the EXECUTE key is pressed, the verification message "Sure?" appears.

```
Uty-3-2      Sure ?
Save         INT → CARD
```

When the EXECUTE key is pressed once more, all programs in the user area are saved on the RAM card inserted in the card slot. After all programs have been saved, the message "Completed" is shown, and the display reverts to the initial screen.

3 Verify a card (CARD Verify)

To call up this page from the Program mode, you press the following keys:

- UTILITY key
↓
- FUNCTION 3 key
↓
- FUNCTION 3 key

```
Uty-3-3      CARD
Verify       INT : CARD
```

This page lets you verify that all programs in the user area are identical to the programs on a card.

When the EXECUTE key is pressed in this condition, the verification process starts.

If all programs on the card are found to be identical to the programs in the internal user area, the display looks as follows.

```
Uty-3-3      Completed
Verify       INT = CARD
```

If there is a mismatch, the display looks as follows.

```
Uty-3-3      Error
Verify       INT ≠ CARD
```

After the verification result was shown, the display reverts to the initial screen.

Formatting a RAM Card

Before a new RAM card can be used, it must be formatted by the 9200. If an unformatted card is inserted in the card slot and a card page menu is selected, the message "CARD Error" appears on the display.

To format a RAM card, proceed as follows.

Insert the unformatted card into the card slot and select the "Card Save" option from the Card page. Following the "CARD Error" indication, the message "FORMAT OK?" flashes on the display.

```
Uty-3-2      CARD
Save         FORMAT OK?
```

If you press the EXECUTE key in this condition, the card will be formatted. After the process is finished, the message "FORMAT Completed" appears and the unit reverts to the "Card Save" page.

```
Uty-3-2      CARD
Save         FORMAT Completed
```

```
Uty-3-2      CARD
Save         INT → CARD
```



CAUTION
Use only the dedicated RAM-32 cards. Other RAM cards cannot be used. The formatting is not compatible with the formatting of RAM cards in the ZOOM 9010. If you want to use a RAM card of the 9010 with the 9200, you must format it once more on the 9200.

Store

This page serves to store the currently selected program in the user area or on a RAM card.

After you press the FUNCTION 4 key at the Utility mode main menu, the currently selected program number flashes, which indicates that this number is being offered as the store target.

```
Uty-4 [ Cross Feedback ]
Store  Buffer → INT/USB
```

When the EXECUTE key is pressed, the following verification message appears.

```
Uty-4
Store  Sure ?
       Buffer → INT/USB
```

When the EXECUTE key is pressed once more, the selected program is stored at the same program number. The following indication briefly appears on the display, and then the unit reverts to the initial Store page.

```
Uty-4      Completed
Store      Buffer → INT/USB
```

If you press the EXIT key while the "Sure?" message is displayed, the Store operation is canceled and the unit reverts to the previous display.



HINT
The functions and operation steps of this page are identical to the Store page in the Edit Utility mode, except for the position of the lit indicators and the fact that the unit reverts to the Program mode when the UTILITY key or EXIT key is pressed. For details on the store operation, please refer to page 37.

Mounting the Unit in a Rack

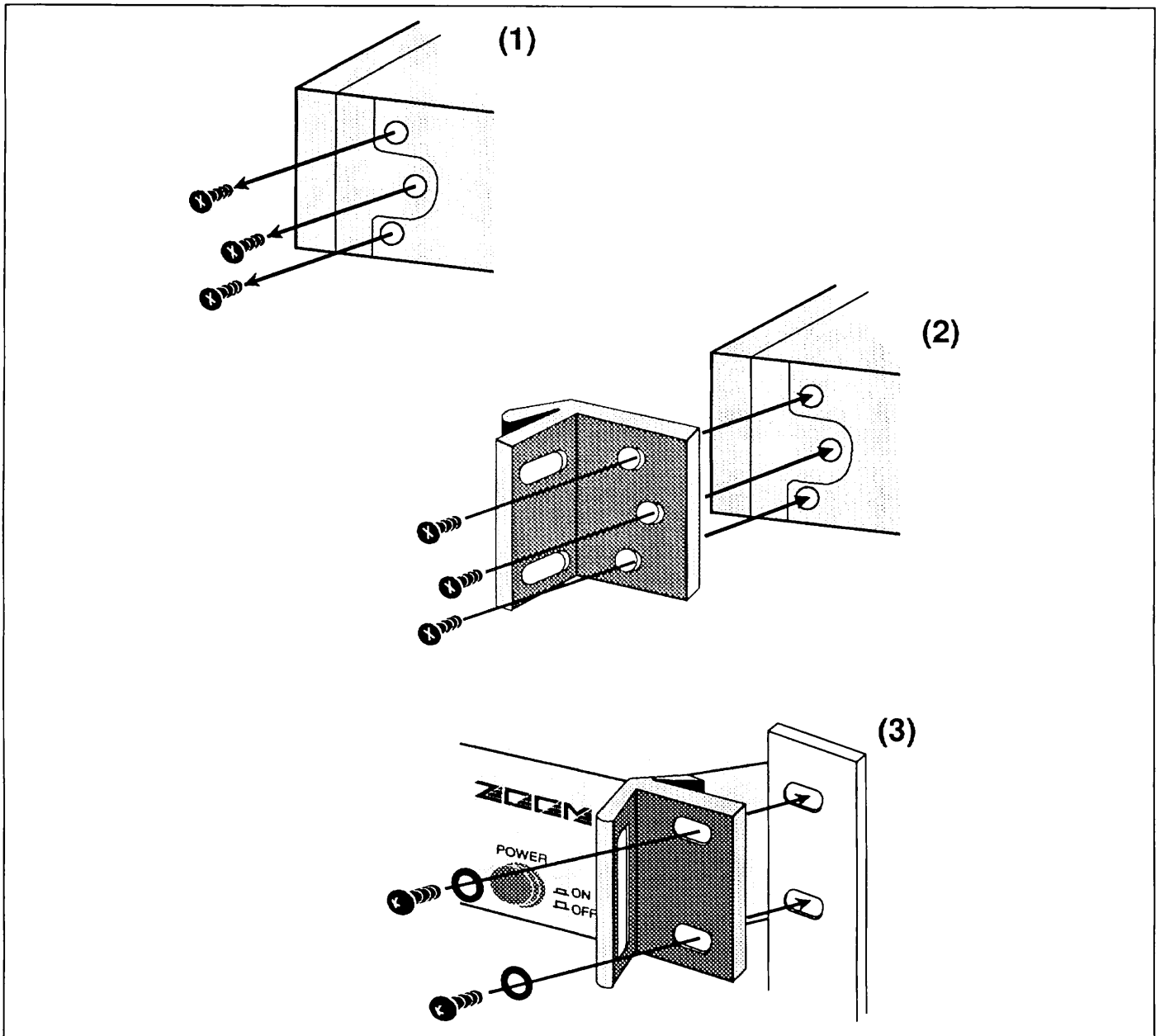

- (1) Remove the three screws on each side.
- (2) Use the removed screws to attach the supplied rack mount brackets to the sides of the unit.
- (3) Fasten the unit to the rack with the two supplied screws on each side.

SPECIFICATIONS

• Frequency Response	16 Hz - 20 kHz
• Dynamic Range	90 dB or better
• Inputs	
Number of Channels	4
Principle	Balanced (pin 1: GND; pin 2: COLD; pin 3: HOT)
Nominal Input Level	+4dBm
Input Impedance	10 k Ω
Connector Type	XLR
• Outputs	
Number of Channels	4
Principle	Unbalanced (pin 1: GND; pin 2: COLD; pin 3: HOT)
Nominal Output Level	+4dBm
Input Impedance	300 Ω
Connector Type	XLR
• A/D Converter	16 bit, linear
• D/A Converter	16 bit, linear
• Sampling Frequency	44.1 kHz
• Programs	
Preset	99
User	99
Card (RAM, ROM)	99
Number of Effects	32
Effect Type A (1-in/1-out)	10 effects Rev 1, Rev 2, E/Ref, Echo, Chors, Phase, Flang, Pitch, Equlz, Gate
Effect Type B (2-in/2-out)	14 effects Rev 1, Rev 2, Rev 3, Rev 4, E/R 1, E/R 2, Echo 1, Echo 2, Chors, Phase, Flang, Pitch, Equlz, Gate
Effect Type C (2-in/2-out)	8 effects Rev 1, Rev 2, Rev 3, Rev 4, Rev 5, Rev 6, Echo, Chors
Front Panel	
Switch	POWER
Keys	FUNCTION/INPUT (1,2,3,4), EDIT ▼, EDIT ▲, SELECT DIAL, UTILITY, MUTE, EXIT, EXECUTE
Control	Rotary knob x 1
LED Readouts	Program number (7 segments x 2) Architecture number (7 segments x 1)
LCD	24 characters x 2 lines (backlit)
Indicators	FUNCTION/INPUT x 4, EDIT, DIAL, UTILITY, MUTE, STEREO, MONO
Input Level Indicator	5-segment LED x 4 (CLIP to -30 dB)
Connectors	CARD slot
Rear Panel	
Volume	LCD CONTRAST
Connectors	INPUT (1,2,3,4), OUTPUT (1,2,3,4), MIDI IN, MIDI OUT
Power Requirements	100 V AC, 50/60 Hz
Power Consumption	28 W
Dimensions	432 (W) x 340.5 (D) x 44 (H) mm EIA 19-inch rack 1 unit
Weight	4.5 kg

MIDI IMPLEMENTATION

REVISION HISTORY;

Ver 1.00 15.May.1992 - First Issue

ZOOM Corp.

TOKYO, JAPAN

Z 4 E - 0 0 0 5 - A 4 P

1. TRANSMITTED DATA

1) CHANNEL VOICE MESSAGES

STATUS	SECOND	THIRD	DESCRIPTION
1011 nnnn	0000 0000	Ohhh hhhh	CONTROL CHANGE MSB of Bank Select hhh hhhh : MSB of Bank No. (See Note 1)
	0010 0000	0111 1111	LSB of Bank Select 111 1111 : LSB of Bank No. (See Note 1)
1100 nnnn	0ppp pppp	---- ----	PROGRAM CHANGE ppp pppp : Program Number

NOTE:

* nnnn = MIDI Channel Number (0000 - 1111)

1. Assignment of Bank No.

0000H - Internal Memory
0001H - Card
3FFFH - Preset Programs

2. The transmitted Program No. is the same as the Program No. displayed on panel LED (actually, displayed No. - 1).

2. RECOGNIZED DATA

1) CHANNEL VOICE MESSAGES

STATUS	SECOND	THIRD	DESCRIPTION
1011 nnnn			CONTROL CHANGE
	0000 0111	0vvv vvvv	Master Effect Level vvv vvvv : Level
	0101 1011	0vvv vvvv	Effect Mute vvv vvvv : Mute ON/OFF (See NOTE 1)
	0000 0000	Ohhh hhhh	MSB of Bank Select hhh hhhh : MSB of Bank No. (See Note 2)
	0010 0000	0111 1111	LSB of Bank Select 111 1111 : LSB of Bank No. (See Note 2)
	0000 0110	Ohhh hhhh	MSB of DATA ENTRY hhh hhhh : Parameter value of MSB.
	0010 0110	0111 1111	LSB of DATA ENTRY 111 1111 : Parameter value of LSB.
	0110 0000	0xxx xxxx	DATA INCREMENT xxx xxxx will be ignored.
	0110 0001	0xxx xxxx	DATA DECREMENT xxx xxxx will be ignored.
	0100 0010	0ppp pppp	LSB of NRPN (See Note 3) ppp pppp : Parameter No.
	0110 0011	0mmm mmmm	MSB of NRPN (See Note 3) mmm mmmm : Effect module No.
1100 nnnn	0ppp pppp	---- ----	PROGRAM CHANGE ppp pppp : Program Number (See NOTE 4)

NOTE:

* nnnn = MIDI Channel Number (0000 - 1111)

1. Effect Mute function is always recognized in BASIC Channel.
When value vvvvvvv is 0, Mute is turned off.
When value vvvvvvv is 127, Mute is turned on.

2. Assignment of Bank No. ;
0000H - Internal Memory
0001H - Card
3FFFH - Preset Programs

3. Assignment of NRPN

NRPN		Parameter
MSB	LSB	
0	0	Module 1 Effect Parameter P1 F1
	1	Effect Parameter P1 F2
	2	Effect Parameter P1 F3
	3	Effect Parameter P1 F4
	4	Effect Parameter P2 F1
	5	Effect Parameter P2 F2
	6	Effect Parameter P2 F3
	7	Effect Parameter P2 F4
	8	Effect Parameter P3 F1
:	:	
1	0	Module 2 Effect Parameter P1 F1
	:	:
2	0	Module 3 Effect Parameter P1 F1
	:	:
3	0	Module 4 Effect Parameter P1 F1
	:	:
7F	0	Program name 1st character
	1	2nd character
	:	:
	15	16th character

4. Relationship between MIDI Program No. and Program No. is assignable.

3. SYSTEM EXCLUSIVE MESSAGE

Transmissible Exclusive messages are also transmitted only while MIDI Thru function is turned off.

All System Exclusive messages are recognized in MIDI Dump Receive Menu only except Communication Request message.

1) Identity Request

BYTE	DESCRIPTION
1111 0000	Exclusive Status
0111 1110	Universal System Exclusive Non-Real Time Header
0nnn nnnn	Channel nnn nnnn : channel 00H-0FH or 7FH (See NOTE 1)
0000 0110	General Information (Sub-ID #1)
0000 0001	Identity Request (Sub-ID #2)
1111 0111	EOX

NOTE:

* Recognized only.

1. When this message is received on channel No. 7fh, it should be recognized on any channel. Then, Identity Reply Message is transmitted on Basic Channel.
(Rule of Universal System Exclusive Message Communication)

2) Identity Reply

BYTE	DESCRIPTION
1111 0000	Exclusive Status
0111 1110	Universal System Exclusive Non-Real Time Header
0nnn nnnn	Channel nnn nnnn : channel 00H-0FH
0000 0110	General Information (Sub-ID #1)
0000 0010	Identity Reply (Sub-ID #2)
0101 0010	ZOOM ID 52H
0000 0100	DEVICE ID 04H (ZOOM 9200)
0000 0000	Reserved of MSB of device code
0000 0000	Reserved of MSB of device code
0000 0000	Reserved of MSB of device code
0sss ssss	1st character of Software Revision Code
0sss ssss	2nd character of Software Revision Code
0sss ssss	3rd character of Software Revision Code
0sss ssss	4th character of Software Revision Code
1111 0111	EOX

NOTE:

- * Transmitted when Identity Request message is recognized.
Software revision code is 4-digit string of ASCII characters.

3) Communication Request

BYTE	DESCRIPTION
1111 0000	EXCLUSIVE STATUS
0101 0010	ZOOM ID 52H
0nnn nnnn	CHANNEL nnn nnnn : channel 00H-0FH or 7FH (See NOTE 1)
0000 0100	DEVICE ID 04H : device No. (ZOOM 9200)
0001 0111	FUNCTION ID 17H : Communication Request
1111 0111	EOX

NOTE:

1. When this message is received on channel No. 7fh, it should be recognized on any channel.

4) Completed

BYTE	DESCRIPTION
1111 0000	EXCLUSIVE STATUS
0101 0010	ZOOM ID 52H
0nnn nnnn	CHANNEL nnn nnnn : channel 00H-0FH
0000 0100	DEVICE ID 04H : device No. (ZOOM 9200)
0001 0100	FUNCTION ID 14H : Completed
1111 0111	EOX

NOTE:

- * This message is transmitted when transmitted Dump is processed successfully, write operation is completed for Write Request message ,or Communication request is accepted.

5) Program Dump

BYTE	DESCRIPTION
1111 0000	EXCLUSIVE STATUS
0101 0010	ZOOM ID 52H
0nnn nnnn	CHANNEL nnn nnnn : channel 00H-0FH or 7FH (See NOTE 1)
0000 0100	DEVICE ID 04H : device No. (ZOOM 9200)
0010 0001	FUNCTION ID 21H : Program Dump
0vvv vvvv	
:	Program Data in Edit Buffer (See NOTE 2)
0vvv vvvv	
1111 0111	EOX

NOTE:

1. When this message is received on channel No. 7fh, it should be recognized on any channel.
2. 8-7 Conversion is used while Program Data is transmitted.

6) Program Dump Request

BYTE	DESCRIPTION
1111 0000	EXCLUSIVE STATUS
0101 0010	ZOOM ID 52H
0nnn nnnn	CHANNEL nnn nnnn : channel 00H-0FH or 7FH (See NOTE 1)
0000 0100	DEVICE ID 04H : device No. (ZOOM 9200)
0001 0001	FUNCTION ID 11H : Program Dump Request
1111 0111	EOX

NOTE:

- * Recognized only.
When this message is recognized, Program Dump message will be transmitted.

1. When this message is received on channel No. 7fh, it should be recognized on any channel. Then, Program Dump message is transmitted on Basic Channel.

7) Write Request

BYTE	DESCRIPTION
1111 0000	EXCLUSIVE STATUS
0101 0010	ZOOM ID 52H
0nnn nnnn	CHANNEL nnn nnnn : channel 00H-0FH or 7FH (See NOTE 1)
0000 0100	DEVICE ID 04H : device No. (ZOOM 9200)
0001 0010	FUNCTION ID 12H : Write Request
0ppp pppp	Program No. ppp pppp : 1 - 99
1111 0111	EOX

NOTE:

* Recognized only.

When this message is recognized, 9200 stores the Program Data in Active Buffer into Program memory #<Program No.> .

1. When this message is received on channel No. 7fh, it should be recognized on any channel.

8) All Programs Dump

BYTE	DESCRIPTION
1111 0000	EXCLUSIVE STATUS
0101 0010	ZOOM ID 52H
0nnn nnnn	CHANNEL nnn nnnn : channel 00H-0FH or 7FH (See NOTE 1)
0000 0100	DEVICE ID 04H : device No. (ZOOM 9200)
0010 0010	FUNCTION ID 22H : All Programs Dump
0vvv vvvv : 0vvv vvvv	whole of Program Data in Memory (See NOTE 2)
1111 0111	EOX

NOTE:

1. When this message is received on channel No. 7fh, it should be recognized on any channel.

2. 8-7 Conversion is used while Program Data is transmitted.

9) All Program Dump Request

BYTE	DESCRIPTION
1111 0000	EXCLUSIVE STATUS
0101 0010	ZOOM ID 52H
0nnn nnnn	CHANNEL nnn nnnn : channel 00H-0FH or 7FH (See NOTE 1)
0000 0100	DEVICE ID 04H : device No. (ZOOM 9200)
0001 0011	FUNCTION ID 13H : All Program Dump Request
1111 0111	EOX

NOTE:

* Recognized only.

When this message is recognized, All Program Dump message will be transmitted.

1. When this message is received on channel No. 7fh, it should be recognized on any channel. Then, All Program Dump message is transmitted on Basic Channel.

10) System data Dump

BYTE	DESCRIPTION
1111 0000	EXCLUSIVE STATUS
0101 0010	ZOOM ID 52H
0nnn nnnn	CHANNEL nnn nnnn : channel 00H-0FH or 7FH (See NOTE 1)
0000 0100	DEVICE ID 04H : device No. (ZOOM 9200)
0010 0010	FUNCTION ID 23H : System Data Dump
0vvv vvvv :	system data (NOTE 2)
0vvv vvvv	
1111 0111	EOX

NOTE:

1. When this message is received on channel No. 7fh, it should be recognized on any channel.
2. System Data Dump includes Input Mode, Program Auto Load On/Off, Program Change Map, and MIDI settings (except MIDI channel).

11) System Data Dump Request

BYTE	DESCRIPTION	
1111 0000	EXCLUSIVE STATUS	
0101 0010	ZOOM ID	52H
0nnn nnnn	CHANNEL	nnn nnnn : channel 00H-0FH or 7FH (See NOTE 1)
0000 0100	DEVICE ID	04H : device No. (ZOOM 9200)
0001 0011	FUNCTION ID	16H : System Data Dump Request
1111 0111	EOX	

NOTE:

* Recognized only.

When this message is recognized, System Data Dump message will be transmitted.

1. When this message is received on channel No. 7fh, it should be recognized on any channel. Then, System Data Dump message is transmitted on Basic Channel.

* 8-7 Conversion

To transmit 8-bit data in MIDI SysEx, any data bytes should be 7-bit data.

First, strip out bit7(MSB) from source 7 bytes of data, and build 1 byte data attaching MSB=0. Then send this byte first, and send 1st - 7th data without MSB. These 8 bytes are combined to 1 block.(Fig.1)

If stream of data is less than 7 bytes, stream bytes + 1 will be the size of the block(Fig.2).

Fig.1

AAAAaaaa BBBBbbbb CCCccccc DDDDDddd EEEEEeee FFFFffff GGGGgggg

↓

0GFEDCBA OAAAAaaa OBBBBbbb OCCccccc ODDDDddd OEEEEeee OFFFffff OGGGgggg

Fig.2

AAAAaaaa BBBBbbbb CCCccccc

↓

0000CBA OAAAAaaa OBBBBbbb OCCccccc

Function ...	Transmitted	Recognized	Remarks
Basic Default Channel Changed	1 - 16 1 - 16	1 - 16 1 - 16	Memorized
Mode Default Messages Altered	1,3 X *****	1,3 X	Memorized
Note Number True voice	X *****	X	
Velocity Note ON Note OFF	X X	X X	
After Key's Touch Ch's	X X	X X	
Pitch Bend	X	X	
Control Change	○ 0, 32	○ 7 6,38,96-99 91 0, 32	Master Effect level NRPN Effect Mute Bank Select
Prog Change True #	○(0-98) *****	○(0-127) *****	
System Exclusive	○	○	
System Song Pos Song Sel Common Tune	X X X	X X X	
System Clock Real Time Commands	X X	X X	
Aux Local ON/OFF All Notes OFF Mes- Active Sense sages Reset	X X X X	X X X X	
Notes			

Mode 1 : OMNI ON, POLY
Mode 3 : OMNI OFF, POLY

Mode 2 : OMNI ON, MONO
Mode 3 : OMNI OFF, MONO

o : Yes
x : No

ZOOM 9200 PROGRAM LIST

Group	No.	Name	Arch	Effects	Fx Link	Comments
Hall	1	Concert Hall	I	[1] C Rev5	—	This program simulates a large concert hall and is ideal for large ensembles. Reverb time is 2.2s, w/45ms.predelay & medium damping.
Hall	2	Huge Hall	I	[1] C Rev3	—	This program simulates a large modern concert hall space. Especially useful for filling out acoustic ensembles. Reverb time is 3.4s, w/25ms. predelay & medium damping.
Hall	3	Long Hall	I	[1] C Rev1	—	This program creates the illusion of great depth behind the listener, with some spread fluctuation an the end. Reverb time is 4.5s, w/70ms of predelay.
Hall	4	Wide Hall	I	[1] C Rev6	—	This program simulates a hall which seems very wide, implying great space without excessive decay. Reverb time is 3.6s, w/30 ms. of predelay and very light damping.
Hall	5	Real Hall	I	[1] C Rev1	—	This hall is programmed with low/midrange frequencies boosted. Initial effect (attack) is emphasized. Reverb time is 3.3s, w/18ms predelay & long initial reflections.
Hall	6	Small Hall	I	[1] C Rev5	—	This program initially creates an illusion of large space, which evaporates with a short decay. Reverb time is 1.7s, w/0.1 ms predelay & fairly strong initial reflections.
Hall	7	Clear Hall	I	[1] C Rev4	—	This hall seems to be made with hard, reflective materials. High frequencies are multiplied above 12.5k. Reverb time is 2.0s, w/11 ms. predelay & very little damping.
Hall	8	Bright Hall	II	[1] B Rev3 [2] B Rev1	Para/Mix	This program is bright space which uses two different reverb algorithms mixed in parallel. Overall reverb time is 3.2s, w/30ms. predelay in one and 0.1ms. in the other.
Hall	9	Ensemble Hall	I	[1] C Rev2	—	This effect can be mixed liberally with source material without building up an overly wet sound. Reverb time is 1.0s, w/10 ms. predelay & attack emphasis 80%.
Hall	10	Church	I	[1] C Rev5	—	Long decay and pronounced reflection simulate the stone walls and high ceilings of a cathedral. Reverb time is 7.0s, w/54ms. predelay & symmetrical reflections at 24/100ms.
Hall	11	Empty Hall	I	[1] C Rev1	—	This simulates a large performance space without an audience to absorb sounds. Excellent cinema effect. Reverb time is 3.4s, w/40ms. predelay & very little damping.
Hall	12	Sports Arena	II	[1] B E/R 1 [2] B Rev4	Para/Mix	This program simulates the echoing acoustics of an arena. Excellent for speaking voice as a cinematic effect. Reverb effect is patched through 140ms. early reflection algorithm.
Hall	13	Hall-EQ	II	[1] B EQ [2] B Rev3	Serial	Here the reverb is sent through a three band EQ, making adjustments to the tonal colour of the effect extremely easy to alter. Basic reverb time is 3.5s, w/75ms. of predelay.
Room	14	Natural Room	I	[1] C Rev1	—	This simulates a medium room without many high frequency reflections, but with full midrange. Reverb time is 1.2s, w/4.0ms. predelay & medium damping.
Room	15	Wide Room	I	[1] C Rev1	—	This program uses diffusion and strong multiple reflections with a short reverb decay to create the 'wide' feeling of this room. Reverb time is 1.5s.
Room	16	Small Chamber	I	[1] C Rev1	—	This chamber enriches any source material, very good for smaller percussion. The high damping gives a round finish to the effect. Reverb time is 0.7s.
Room	17	Live Salon	I	[1] C Rev1	—	This simulates a medium sized room with somewhat reflective surfaces. Reverb time is 1.0s, w/0.1ms. predelay & light damping.
Room	18	Rehearsal Room	I	[1] C Rev1	—	This program is a very realistic simulation of a small to medium sized rehearsal space. Reverb time is 0.7s, w/17 ms. predelay, light damping, and medium diffusion.
Room	19	Dance Club	I	[1] C Rev1	—	This reverb simulates a bright club room with effect attack emphasized to simulate stage sound. Reverb time is 1.0s, w/0.1 ms. predelay & attack parameter at 77%.
Room	20	Empty Room	II	[1] B E/R1 [2] B Rev2	Para/Mix	This program sends the reverb into an early reflection algorithm and mixes the signals in parallel. Reverb time is 1.0s, w/20ms. predelay & medium damping.
Room	21	Meeting Room	I	[1] C Rev1	—	This simulates a small to medium sized room. It is excellent for enhancing a speaking voice. Reverb time is 0.5s, w/0.1ms. predelay & medium damping.
Room	22	Locker Room	II	[1] B Rev1 [2] B E/R1	Serial	This suggests low ceilings and metal and tile surfaces. Short 1st and 2nd reflections make a tunneled sound. Reverb time is 1.2s, w/20ms. predelay & high damping.
Room	23	Bath Room	II	[1] B Rev1 [2] B E/R1	Para/Mix	This simulates a small, tiled room with clear reflections, but without much decay. Reverb time is 0.5s, w/20ms. predelay, medium damping, and attack emphasis.
Room	24	Room-EQ	II	[1] B EQ [2] B Rev1	Serial	Here the reverb is sent through a three band EQ, making adjustments to the tonal colour of the effect extremely easy to alter. Basic reverb time is 0.9s, w/0.1ms. of predelay.

Group	No.	Name	Arch	Effects	Fx Link	Comments
Plate	25	Natural Plate	I	[1] C Rev6	—	This program simulates a plate reverb sound, with low frequency boost, and reverb peaks at 500Hz and 8kHz. Basic reverb time is 3.8s, w/80ms. of predelay.
Plate	26	Big Plate	I	[1] C Rev6	—	This program simulates an exceptionally large plate, with asymmetrical reflections and extreme frequency peaks. Basic reverb time is 7.5s, w/140ms. of predelay.
Plate	27	Small Plate	I	[1] C Rev1	—	Like the Small Hall, this program initially suggests a large sound with fairly strong reflections, but then closes down. Basic reverb time is 2.4s, w/70ms. of predelay.
Plate	28	Wide Plate	I	[1] C Rev6	—	This responsive, bright plate simulation moves in the stereo image with asymmetrical reflections. Basic reverb time is 4.5s, w/50ms. of predelay, and almost no damping.
Plate	29	Clear Plate	I	[1] C Rev6	—	This bright plate also moves, but using the spread parameter, which begins in the center and spread out. Basic reverb time is 2.6s, w/55ms. of predelay.
Plate	30	Real Plate	I	[1] C Rev6	—	This plate's tonal richness comes from open Hi Cut parameter balanced by opposite settings in the EQ. Basic reverb time is 3.2s, w/70ms. of predelay.
Plate	31	Percussion	I	[1] C Rev2	—	This reverb fattens the source material initially, and then subsides evenly, without pronounced reflections. Reverb time is 2.0s, w/0.1ms. of predelay & medium damping.
Plate	32	Vocal Plate	I	[1] C Rev6	—	This program is a bright and open reverb sound with resonant peaks at 4 and 16kHz. Customize the tone with EQ. Basic reverb time is 2.6s, w/70ms. of predelay.
Plate	33	Warm Plate	I	[1] C Rev6	—	This warm tonality is created with EQ and resonant peaks at 350Hz and 3kHz, while damping is low for an even decay. Basic reverb time is 3.8s, w/78ms. of predelay.
Plate	34	Hi Remain Plate	I	[1] C Rev1	—	This high pass reverb effect is created by multiplying frequencies over 2kHz which finally spread to the sides. Basic reverb time is 2.4s, w/90ms. of predelay.
Plate	35	Dark Shadow	I	[1] C Rev5	—	This low pass effect scales frequencies above 800Hz by 50%, with added help from EQ. Basic reverb time is 4.7s, w/110ms. of predelay, and surprisingly little damping.
Plate	36	Plate-EQ	II	[1] B EQ [2] B Rev1	Serial	Here the reverb is sent through a three band EQ, making adjustments to the tonal colour of the effect extremely easy to alter. Basic reverb time is 3.4s, w/60ms. of predelay.
Plate	37	Natural Ambience	I	[1] C Rev1	—	This program enhances the source material with attack emphasis, and then decays quickly with high damping. Basic reverb time is 0.9s, w/7ms. of predelay.
Ambience	38	Shallow Ambience	II	[1] B Rev1 [2] B E/R2	Para/Mix	This program patches an early reflection algorithm through a very short reverb with medium attack emphasis. Reverb time is 0.5s, w/0.1ms. of predelay, and light damping.
Ambience	39	Broad Ambience	II	[1] B Rev1 [2] B E/R2	Para/Mix	This program sends the early reflection through a longer brighter reverb, with asymmetrical reflections. Basic reverb time is 1.6s, w/30ms. of predelay.
Ambience	40	Tight Ambience	II	[1] B Rev1 [2] B E/R2	Para/Mix	Similar to program 38, but brighter. Sounds great with Latin Percussion, adding presence and body. Basic reverb time is 0.6s, w/0.1ms. of predelay & light damping.
Ambience	41	Infinity	I	[1] C Rev5	—	This program does just what it says - for a full 30min! Try altering the damping, attack, and Hi Multiply/Xover. Basic reverb time is 30minutes, w/0.1ms. of predelay.
Ambience	42	Power Ambience	II	[1] B Rev1 [2] B E/R2	Para/Mix	Another early reflection algorithm parallel patched through reverb, this program reinforces bass, adding body to acoustic snares. Reverb time is 0.9s, w/0.1ms. of predelay.
Ambience	43	Wood Wall	I	[1] C Rev1	—	This unique tone first multiplies highs over 4kHz, and then suppresses 10kHz with EQ for a filter envelope effect. Basic reverb time is 0.5s, w/15ms. of predelay.
Ambience	44	Cool Ambience	II	[1] B Rev2 [2] B E/R1	Para/Mix	Now the first early reflection algorithm if Hi Cut and then parallel patched into a very bright, long reverb. Basic reverb time is 3.6s, w/60ms. of predelay.
Ambience	45	Warm Ambience	II	[1] B Rev1 [2] B Rev4	Para/Mix	Two very long, dark reverbs are mixed in parallel. Excellent for rescuing sampled strings that lack a filter. Basic reverb time is 4.0s, w/50ms. of predelay.
Ambience	46	Prison Door	II	[1] B Rev4 [2] B Rev2	Para/Mix	Here are two dark reverbs mixed in parallel with staggered reflections dramatically offset predelays. Reverb times are 4.2/3.4s, predelays are 35/300ms.
Ambience	47	Tonal Enhance	I	[1] C Rev3	—	This program is ideal for filling out solo lead instruments. Decay time can be shortened by scaling the Hi Multiply. Basic reverb time is 0.4s, w/0.1ms. of predelay.
Ambience	48	Ambience-EQ	II	[1] B EQ [2] B Rev1	Serial	Here the reverb is sent through a three band EQ, making adjustments to the tonal colour of the effect extremely easy to alter. Basic reverb time is 1.7s, w/10ms. of predelay.
Echo	49	Big Dome	II	[1] B Echo1 [2] B Rev2	Para/Mix	This programs has patches the reverb through an echo set to 222ms. mixed on parallel. Basic reverb time is 3.0s, w/50ms. of predelay.

Group	No.	Name	Arch	Effects	Fx Link	Comments
Echo	50	Gymnasium	II	[1] B E/R1 [2] B Rev2	Para/Mix	This program patches a long reverb through an early reflection algorithm to simulate a large reflective space. Basic reverb time is 3.4s, w/60ms. of predelay.
Echo	51	Airport Lobby	IV	[1] A Rev2 [3] A Echo [2] A Rev2 [4] A Echo	Serial	Two echoes and two reverbs combine to create the varied and many shaped reflections of an airport lobby. Basic reverb times are 1.8s, delays are 340 and 470ms.
Echo	52	Echo Reverb	II	[1] B Rev2 [2] B Echo1	Serial	The name says it all. Basic reverb time is 2.8s, w/0.1ms. of pre-delay. The delay is set at 250ms. W/Xfeedback set at 55%. The Xpanning effect works in mono mode only.
Echo	53	Solo Lead	II	[1] B Rev3 [2] B Echo1	Serial	This program feeds a 420ms echo, w/Xfeedback into a reverb. Basic reverb time is 2.3s, w/25ms. of pre-delay. As before, the Xpanning effect requires mono mode.
Echo	54	After Wave	III	[1] B Rev4 [3] A Echo [2] A Rev1	Serial	This program creates a special effect by patching an echo and reverb through a stereo reverb in series. Delay is set at 740ms., reverb time is 3.4s., w/0.1ms of pre-delay.
Echo	55	Tunnel	II	[1] B Rev4 [2] B Rev4	Para/Mix	This program links two reverb algorithms in parallel, with offset predelay and reflection in each. Basic reverb times are 1.2/3.0s, predelay is 0.5 and 200ms.
Echo	56	Long Shadow	II	[1] B Rev4 [2] B Echo1	Serial	Here a 380 ms delay travels in series to an extremely long reverb. Best used with long, continuous tones. Basic reverb time is 12s, w/predelay at 220ms.
Echo	57	Slappy Echo	I	[1] C Echo	—	This special effect uses a nervous 39ms delay time, with 75% Xfeedback. The Xpanning only works in mono mode.
Echo	58	Stereoizer	IV	[1] A Echo [3] A Echo [2] A Echo [4] A Echo	Para/Mix	This echo effect works well to broaden any mono source without pitch shifting.
Echo	59	KARA-OK	III	[1] B Rev3 [3] A Echo [2] A Echo	Para/Mix	The obvious delay effects patched into reverb fill out vocals in a special way. Great for cinema karaoke scenes. Reverb time is 2.2s, and delays are 135ms.
Echo	60	Cross Feedback	I	[1] C Echo	—	Delay time is 250ms. Xfeedback is 45% with no damping over the decay. As before, the Xpanning effect only works in mono mode.
Chorus	61	Ambient Chorus	II	[1] B Rev1 [2] B Chors	Serial	This program patches chorus into reverb in series. Great for acoustic or electric guitar. Reverb time is 2.7s, w/0.1ms. pre-delay, & 100% attack emphasis to enhance source.
Chorus	62	Water Chorus	II	[1] B Chors [2] B Rev2	Serial	Now the reverb sound is patched into the chorus setting, making a soft, ethereal wash. Good for spacy textures. Reverb time is 3.0s, w/1ms of pre-delay.
Chorus	63	Monster Chorus	III	[1] B Rev4 [3] A Chors [2] A Chors	Serial	This program uses two separate chorus algorithms before patching through to the reverb in series. Basic reverb time is 3.0s, w/16ms. of pre-delay.
Chorus	64	Chorus-Amb.	II	[1] B E/R1 [2] B Chors	Serial	This program patches chorus into one of the early reflection algorithms in series.
Chorus	65	E/R-Chorus	II	[1] B Chors [2] B E/R1	Serial	This program reverses the series patching in program 64. Best used with continuous tones.
Chorus	66	Space Chorus	II	[1] B Chors [2] B Rev1	Serial	Patching the extremely long reverb into the chorus in series creates a very watery effect. Basic reverb time is 4.5s, w/100ms. of pre-delay.
Flange	67	Cymbal Flange	II	[1] B Rev2 [2] B Flang	Serial	Here, a flange with extreme modulation is sent to the reverb for a bizarre effect. Try with cymbals. Basic reverb time is 2.6s, w/0.1ms. of pre-delay.
Flange	68	Rev 2 Flanger	II	[1] B Flang [2] B Rev2	Serial	This sound reverses the series in program 67, sending the reverb into the flange for a very spacy effect. Basic reverb time is 2.0s, w/6ms. of pre-delay.
Flange	69	Fla Fla Rev.	III	[1] B Rev4 [3] A Flang [2] A Flang	Serial	Two flangers with varied parameters feed a reverb. Basic reverb time is 1.9s, w/0.1ms. of pre-delay.
Flange	70	Flange Feedback	II	[1] B Flang [2] B Echo1	Serial	Echo is patched in series through to the flanger with 70% feedback and 40% modulation depth. Delay time is 250ms.
Flange	71	Space Flange	II	[1] B Flang [2] B Rev2	Serial	Patching the long reverb into the flanger yields a spacy effect. Basic reverb time is 4.5s, w/100ms. of pre-delay.
Flange	72	Space Gun	II	[1] B Flang [2] B Rev2	Serial	Here the 15Hz modulation in the flanger gives great gun. Best effect for 50's sci-fi movies. Basic reverb time is 3.0s, w/100ms. of pre-delay.
Phase	73	Phase Reverb	II	[1] B Rev2 [2] B Phase	Serial	This phaser program is great for adding life to old tech synths. Basic reverb time is 2.1s, w/7.5ms. of pre-delay.
Phase	74	Crybaby Reverb	IV	[1] A Rev2 [3] A Phase [2] A Rev2 [4] A Phase	Serial	Two phasers with slightly different modulation frequencies patched into two reverbs yields this ersatz filter effect. Basic reverb time is 1.0s, w/0.1ms. of pre-delay.

Group	No.	Name	Arch	Effects	Fx Link	Comments
Phase	75	Space Phase	II	[1] B Phase [2] B Rev1	Serial	Reverb into phaser creates this spacy effect. Try using on bass patches. Basic reverb time is 4.5s, w/40ms. of predelay.
Phase	76	Undulator	II	[1] B Phase [2] B Echo1	Serial	This program sends the echo signal into the phaser. Try with electric guitar. Digital delay time is 250ms, with 50% Xfeedback. Use in mono mode for panning.
Phase	77	Phase by Phase	II	[1] B Phase [2] B Phase	Para/Mix	Two phasers are patched in series with different modulation speeds and inverted phase create an interesting effect for synth sounds.
Pitch	78	Double Shift	IV	[1] A Rev1 [3] A Pitch [2] A Rev1 [4] A Pitch	Serial	Here one pitch shifter tunes the signal up 8 cents, and the other down 8 cents patching serially into the verb. For vocals. Reverb time is 0.8s, w/25ms. of predelay.
Pitch	79	Octaves Vox	III	[1] B Rev2 [3] A Pitch [2] A Pitch	Serial	First, the pitch shifters creates a detuned octave below signal. This is sent into the reverb for an interesting vocal effect. Basic reverb time is 3.1s, w/18ms. of predelay.
Pitch	80	Delay Shift Rev	III	[1] B Echo1 [3] A Pitch [2] A Pitch	Serial	The pitch shifters create a detuned octave below the signal, which is then sent to the echo in series. Delay time is 250ms, w/50% Xfeedback.
Pitch	81	Idol Plate	II	[1] B Rev1 [2] B Pitch	Serial	For singers who may sing flat, this pitch shifter raises pitch 8 cents, and then goes on to the reverb. Basic reverb time is 3.1s, w/256ms. of predelay.
Pitch	82	Honky Room	II	[1] B E/R1 [2] B Pitch	Para/Mix	The ever-popular, ultra-detuned sound of the 'honky tonk' piano created with this program with pitch shifting and early reflection algorithms.
Pitch	83	Harmonize Echo	III	[1] B Rev1 [3] A Pitch [2] A Pitch	Serial	Two pitch shifters create a harmony around the source signal (-3/+4 semitones) which is delayed by a 220ms. echo.
Gate	84	Power Gate	III	[1] B Rev2 [3] A Pitch [2] A Pitch	Serial	First the reverb fattens the signal with 100% attack emphasis, and then it goes to a 60ms gate. Snare heaven. Basic reverb time is 2.2s, w/0.1ms. of predelay.
Gate	85	Knock Gate Rev	II	[1] B Gate [2] B Rev1	Serial	This program begins with a delayed reverb patched serially into a 30ms. noise gate, making a slow slapback effect. Basic reverb time is 2.0s, w/125ms. of predelay.
Gate	86	Reverb-Gate	II	[1] B Gate [2] B Rev1	Serial	This program generates a 160ms. gated rush of pink noise by sending a bright, equalized reverb into a noise gate. Basic reverb time is 2.3s, w/0.1ms. of predelay.
Gate	87	Reverse Gate	II	[1] B Gate [2] B E/R2	Serial	This bright reverse gated reverb is created with an early reflection algorithm using a negative tap angle into a 340 ms. noise gate. Use the reverb EQ to change tone.
Gate	88	Smooth Gate	II	[1] B Gate [2] B Rev1	Serial	Here, a reverb is gated with a hold time of 100ms. To make the gate steeper, turn the release down. To alter the tone, change the Hi Cut and Damping of the reverb.
Gate	89	Slow Gate Reverb	II	[1] B Gate [2] B Rev4	Serial	This is a gated reverb with 70ms. hold and ample release time. Play with the gate Xover parameter to get different tonal shapes in the decay.
Gate	90	Hi-Pass Gate	II	[1] B Gate [2] B Rev1	Serial	This unique sound is created with the Xover in the noise gate, set at 25kHz. Lowering this to 0Hz yields a free reverb, raising to 8kHz leaves only very high frequencies.
Gate	91	Gatemolo Reverb	II	[1] B Rev2 [3] A Gate [2] A Gate	Serial	This tremolo effect is created using the trigger mask parameter of the noise gate - to change tempo of the tremolo, change this parameter in both modules 2 & 3.
Template	92	36th Chorus	I	[1] C Chors	—	This is a template setup for using the 36 voice chorus effect.
Template	93	Quad Delay	IV	[1] A Echo [3] A Echo [2] A Echo [4] A Echo	OFF	This template has a default 250ms. delay set up for each module. Use mono input mode to get four discrete echo paths, or stereo for bi-controllable pairs.
Template	94	Twin EQ	II	[1] B EQ [2] B EQ	OFF	This is a template for using 2 stereo EQs. Although the same dual 3-band EQs can be constructed with program 95, the B EQs change both sides simultaneously.
Template	95	Quad EQ	IV	[1] A EQ [3] A EQ [2] A EQ [4] A EQ	OFF	This is a template for using 4 EQs simultaneously. They can be used to process 4 discrete signals, or as dual stereo EQs (see next), or as a serial-linked stereo 6-band EQ.
Template	96	Twin Gate	II	[1] B Gate [2] B Gate	OFF	This is a template for using 2 stereo gates. Although the same dual gates can be constructed with program 94, the B Noise Gates change both sides simultaneously.
Template	97	Quad Gate	IV	[1] A Gate [3] A Gate [2] A Gate [4] A Gate	OFF	This is template for using 4 gates simultaneously. They can be used as noise gates for 4 discrete signals or as linked tremolo modules.
Template	98	Tri Reverb	III	[1] B Rev2 [3] A Rev [2] A Rev	OFF	This is an excellent choice for mixing down multitracks: use the stereo reverb in module 1 for most of the mix, and reserve modules 3 and 4 for snare or solo tracks.
Template	99	Quad Reverb	IV	[1] A Rev1 [3] A Rev2 [2] A Rev1 [4] A Rev2	OFF	This template has for independent reverb lines. Use mono input mode to get four discrete echo paths, or stereo for bi-controllable pairs.

ZOOM

High-Tech Tools for Artistic Expression

ZOOM CORPORATION

3-5-12 Sotokanda Chiyoda-ku, Tokyo 101 Japan.

Tel: (03) 5256-1741. Fax: (03) 5256-1743.

385 Oyster Point Boulevard, # 7, South San Francisco, California 94080, USA.

Tel: (415) 873-5885. Fax: (415) 873-5887.